

**SECTION 1 (Maximum Marks: 12)**

- This section contains **FOUR (04)** questions.
- Each question has **FOUR** options (A), (B), (C) and (D). **ONLY ONE** of these four options is the correct answer.
- For each question, choose the option corresponding to the correct answer.
- Answer to each question will be evaluated **according to the following marking scheme**:  
*Full Marks* : +3 If **ONLY** the correct option is chosen;  
*Zero Marks* : 0 If none of the options is chosen (i.e. the question is unanswered);  
*Negative Marks* : -1 In all other cases.

Q.1 Consider the function  $f: (0, \infty) \rightarrow (-\infty, \infty)$  given by

$$f(x) = \sqrt{x} \log_e(x) - x + 1.$$

Then which one of the following statements is TRUE ?

(A)	The derivative of the function $f$ is decreasing in the interval $(0, 1)$
(B)	The function $f$ has a local maximum at some point $a \in (0, \infty)$
(C)	The function $f$ has a local minimum at some point $b \in (0, \infty)$
(D)	The function $f$ has <b>NEITHER</b> a point of local maximum <b>NOR</b> a point of local minimum in the interval $(0, \infty)$

**Answer Q1: D**

Q.2 Let  $P$  be the point on the parabola  $y = x^2$  such that the slope of the tangent to the parabola at the point  $P$  is 4. Let  $Q$  be the point in the first quadrant lying on the circle  $x^2 + y^2 = 2$  such that the slope of the tangent to the circle at the point  $Q$  is  $-1$ . Let  $R$  be the point in the first quadrant lying on the ellipse  $x^2 + 4y^2 = 8$  such that the slope of the tangent to the ellipse at the point  $R$  is  $-\frac{1}{2}$ . Then the radius of the circle passing through the points  $P, Q$  and  $R$  is

(A)	$\sqrt{10}$	(B)	$\sqrt{5}$	(C)	$\sqrt{\frac{5}{2}}$	(D)	$2\sqrt{5}$
-----	-------------	-----	------------	-----	----------------------	-----	-------------

**Answer Q2: C**

Q.3 Which one of the following matrices can be obtained by performing elementary row transformations on the  $3 \times 3$  identity matrix ?

(A)	$\begin{bmatrix} 1 & 1 & 1 \\ 1 & 1 & 1 \\ 1 & 1 & 1 \end{bmatrix}$	(B)	$\begin{bmatrix} 1 & 1 & 1 \\ 2 & 3 & 4 \\ 1 & 2 & 1 \end{bmatrix}$
(C)	$\begin{bmatrix} 1 & 1 & 1 \\ 2 & 3 & 4 \\ 2 & 5 & 8 \end{bmatrix}$	(D)	$\begin{bmatrix} 1 & 1 & 1 \\ -1 & 1 & 2 \\ 0 & 2 & 3 \end{bmatrix}$

**Answer Q3: B**

Q.4 Considering only the principal values of the inverse trigonometric functions, the value of

$$\cot^{-1}(\cot(-11)) + 10 \sin\left(2 \cos^{-1}\left(\frac{1}{\sqrt{2}}\right)\right) + 10 \sin(2 \tan^{-1}(2))$$

is

(A)	$3\pi + 7$	(B)	$7$	(C)	$4\pi + 7$	(D)	$3\pi - 5$
-----	------------	-----	-----	-----	------------	-----	------------

**Answer Q4: C**

**SECTION 2 (Maximum Marks: 16)**

- This section contains **FOUR (04)** questions.
- Each question has **FOUR** options (A), (B), (C) and (D). **ONE OR MORE THAN ONE** of these four option(s) is(are) correct answer(s).
- For each question, choose the option(s) corresponding to (all) the correct answer(s).
- Answer to each question will be evaluated **according to the following marking scheme**:
  - Full Marks* : +4 **ONLY** if (all) the correct option(s) is(are) chosen;
  - Partial Marks* : +3 If all the four options are correct but **ONLY** three options are chosen;
  - Partial Marks* : +2 If three or more options are correct but **ONLY** two options are chosen, both of which are correct;
  - Partial Marks* : +1 If two or more options are correct but **ONLY** one option is chosen and it is a correct option;
  - Zero Marks* : 0 If none of the options is chosen (i.e. the question is unanswered);
  - Negative Marks* : -1 In all other cases.
- For example, in a question, if (A), (B) and (D) are the **ONLY** three options corresponding to correct answers, then
  - choosing **ONLY** (A), (B) and (D) will get +4 marks;
  - choosing **ONLY** (A) and (B) will get +2 marks;
  - choosing **ONLY** (A) and (D) will get +2 marks;
  - choosing **ONLY** (B) and (D) will get +2 marks;
  - choosing **ONLY** (A) will get +1 mark;
  - choosing **ONLY** (B) will get +1 mark;
  - choosing **ONLY** (D) will get +1 mark;
  - choosing no option (i.e. the question is unanswered) will get 0 marks; and
  - choosing any other combination of options will get -1 marks.

- Q.5 Suppose that Box I contains 6 red balls and 9 green balls, and Box II contains 8 red balls and 12 green balls. All the balls of Box I and Box II are mixed together and a ball is chosen at random from them. Let  $E_1$  be the event that the ball chosen belonged to Box I and let  $E_2$  be the event that the ball chosen belonged to Box II. Let  $F_1$  be the event that the ball chosen is red and let  $F_2$  be the event that the ball chosen is green.

Then which of the following statements is (are) TRUE ?

(A)	The events $E_1$ and $F_1$ are independent
(B)	The events $E_2$ and $F_2$ are dependent
(C)	The conditional probability $P(F_1   E_1)$ is equal to the conditional probability $P(F_1   E_2)$
(D)	The conditional probability $P(F_1   E_1)$ is greater than the conditional probability $P(F_2   E_2)$

**Answer Q5: AC**

Q.6 Let  $P$  be the plane such that it contains the straight line  $\frac{x-1}{2} = \frac{y-3}{3} = \frac{z+2}{1}$  and is perpendicular to the plane  $x + 2y + 3z = 4$ . Let  $P_1$  be the plane which passes through the point  $(4, 2, 2)$  and is parallel to  $P$ .

Then which of the following statements is (are) TRUE ?

(A)	The equation of the plane $P$ is $7x - 5y + z = -10$
(B)	The distance between the planes $P$ and $P_1$ is 30
(C)	The distance of the plane $P$ from the origin is $2\sqrt{3}$
(D)	The acute angle between the plane $P$ and the plane $2x + 2y + z = 3$ is $\cos^{-1}\left(\frac{1}{3\sqrt{3}}\right)$

**Answer Q6: AD**

Q.7 Let  $\mathbb{R}$  denote the set of all real numbers. Let  $f : \mathbb{R} \rightarrow \mathbb{R}$  be an arbitrary function and let  $g : \mathbb{R} \rightarrow \mathbb{R}$  be the function defined by

$$g(x) = xf(x), \text{ for all } x \in \mathbb{R}.$$

Then which of the following statements is (are) TRUE ?

(A)	The function $g$ is always continuous at $x = 0$
(B)	If $f$ is continuous at $x = 0$ , then $g$ is differentiable at $x = 0$
(C)	If $g$ is differentiable at $x = 0$ , then $f$ is continuous at $x = 0$
(D)	If $g$ is differentiable at $x = 0$ , then $\lim_{x \rightarrow 0} f(x)$ exists

**Answer Q7: BD**

Q.8

Consider the matrix

$$M = \begin{bmatrix} 2 & -1 \\ 1 & 0 \end{bmatrix}.$$

Let  $p, q, r, s, a, b, c$  and  $d$  be integers such that

$$M^{26} = \begin{bmatrix} p & q \\ r & s \end{bmatrix} \quad \text{and} \quad \sum_{k=1}^{26} M^k = \begin{bmatrix} a & b \\ c & d \end{bmatrix}.$$

Then which of the following statements is (are) TRUE ?

(A)	There exists a $2 \times 2$ invertible matrix $N$ with real entries such that $MN = N \begin{bmatrix} 1 & 1 \\ 0 & 1 \end{bmatrix}$
(B)	The value of $a$ is 378
(C)	For any two given integers $m$ and $n$ , there exist unique integers $x$ and $y$ such that $px + qy = m \quad \text{and} \quad rx + sy = n$
(D)	For each positive real number $t$ , the system of linear equations $\begin{aligned} (a + t)x + by &= 1 \\ cx + (d + t)y &= -1 \end{aligned}$ has a unique solution

**Answer Q8: ACD**

**SECTION 3 (Maximum Marks: 16)**

- This section contains **FOUR (04)** questions.
- The answer to each question is a **NUMERICAL VALUE**.
- For each question, enter the correct numerical value corresponding to the answer in the designated place using the mouse and the on-screen virtual numeric keypad.
- If the numerical value has more than two decimal places, **truncate/round-off** the value to **TWO** decimal places.
- Answer to each question will be evaluated **according to the following marking scheme**:  
*Full Marks* : +4 If **ONLY** the correct numerical value is entered in the designated place;  
*Zero Marks* : 0 In all other cases.

Q.9 Let  $S = \{1, 2, 3, \dots, 10\}$ . Consider the set

$$X = \{R : R \text{ is an equivalence relation on the set } S \text{ such that } R \text{ has exactly 42 elements}\}.$$

Then the number of elements in  $X$  is \_\_\_\_\_.

**Answer Q9: [2520]**

Q.10 Consider the function  $f : \left(-\frac{\pi}{2}, \frac{\pi}{2}\right) \rightarrow (-\infty, \infty)$  defined by

$$f(x) = (|x| + |x - 1|) \sin x + [x \sin x],$$

where  $[x \sin x]$  is the greatest integer less than or equal to  $x \sin x$ .

Let  $\alpha$  be the total number of points in the interval  $\left(-\frac{\pi}{2}, \frac{\pi}{2}\right)$  at which  $f$  is **NOT** continuous, and let  $\beta$  be the total number of points in the interval  $\left(-\frac{\pi}{2}, \frac{\pi}{2}\right)$  at which  $f$  is **NOT** differentiable.

Then the value of  $\alpha + \beta$  is \_\_\_\_\_.

**Answer Q10: [5]**

Q.11 The number of ways to distribute 10 identical red pens and 14 identical blue pens among four persons such that each person gets 6 pens, is \_\_\_\_\_.

**Answer Q11: [206]**

Q.12

Let

$$\alpha = \left(1 - 2 \cos\left(\frac{\pi}{11}\right)\right) \left(1 - 2 \cos\left(\frac{3\pi}{11}\right)\right) \left(1 - 2 \cos\left(\frac{9\pi}{11}\right)\right) \left(1 - 2 \cos\left(\frac{27\pi}{11}\right)\right) \left(1 - 2 \cos\left(\frac{81\pi}{11}\right)\right).$$

Then the value of  $5 - \alpha^2$  is \_\_\_\_\_.**Answer Q12: [3.9 TO 4.1]**

## SECTION 4 (Maximum Marks: 16)

- This section contains **FOUR (04)** Matching List Sets.
- Each set has **ONE** Multiple Choice Question.
- Each set has **TWO** lists: **List-I** and **List-II**.
- **List-I** has **Four** entries (P), (Q), (R) and (S) and **List-II** has **Five** entries (1), (2), (3), (4) and (5).
- **FOUR** options are given in each Multiple Choice Question based on **List-I** and **List-II** and **ONLY ONE** of these four options satisfies the condition asked in the Multiple Choice Question.
- Answer to each question will be evaluated **according to the following marking scheme**:  
*Full Marks* : +4 **ONLY** if the option corresponding to the correct combination is chosen;  
*Zero Marks* : 0 If none of the options is chosen (i.e. the question is unanswered);  
*Negative Marks* : -1 In all other cases.

Q.13

Match each entry in List-I to the correct entry in List-II and choose the correct option.

**List-I**

(P) If  $\alpha$  and  $\beta$  are the distinct roots of the equation  $x^2 + x + 1 = 0$ , then the quadratic equation with roots  $\frac{1}{(\alpha+1)^{2026}}$  and  $\frac{1}{(\beta+1)^{2026}}$  is

(Q) If  $\alpha$  and  $\beta$  are the distinct roots of the equation  $x^2 + x + 1 = 0$ , then the quadratic equation with roots  $\frac{1}{(\alpha+1)^{2027}}$  and  $\frac{1}{(\beta+1)^{2027}}$  is

(R) If  $\gamma$  and  $\delta$  are the distinct roots of the equation  $x^2 - x + 1 = 0$ , then the value of  $\frac{1}{(\gamma-1)^{2026}} + \frac{1}{(\delta-1)^{2026}}$  is

(S) If  $p$  and  $r$  are the distinct roots of the equation  $x^2 + x - 1 = 0$ , then the value of  $\frac{1}{(p+1)^3} + \frac{1}{(r+1)^3}$  is

**List-II**

(1)  $x^2 + x + 1 = 0$

(2)  $x^2 - x + 1 = 0$

(3)  $x^2 + x - 1 = 0$

(4)  $-1$

(5)  $-4$

(A)	(P) $\rightarrow$ (1), (Q) $\rightarrow$ (2), (R) $\rightarrow$ (5), (S) $\rightarrow$ (4)
(B)	(P) $\rightarrow$ (3), (Q) $\rightarrow$ (1), (R) $\rightarrow$ (4), (S) $\rightarrow$ (5)
(C)	(P) $\rightarrow$ (1), (Q) $\rightarrow$ (2), (R) $\rightarrow$ (4), (S) $\rightarrow$ (5)
(D)	(P) $\rightarrow$ (2), (Q) $\rightarrow$ (3), (R) $\rightarrow$ (5), (S) $\rightarrow$ (4)

**Answer Q13: C**

Q.14

Match each entry in List-I to the correct entry in List-II and choose the correct option.

**List-I****List-II**

(P) The number of elements in the set

(1) is 1

$$\{x \in [-\pi, \pi] : \sin^6 x + \cos^4 x = 1\}$$

(Q) The number of elements in the set

(2) is 2

$$\left\{x \in \left[-\frac{\pi}{2}, \frac{\pi}{2}\right] : \sin^2 x + \cos^6 x = 1\right\}$$

(R) The number of elements in the set

(3) is 3

$$\left\{x \in [-\pi, \pi] : \cos^2\left(\frac{x}{2}\right) - \sin^2 x = \frac{1}{2}\right\}$$

(S) The number of elements in the set

(4) is 4

$$\left\{x \in [-2\pi, 2\pi] : 6 \sin^2\left(\frac{x}{2}\right) - \cos 3x = 3\right\}$$

(5) is 5

(A)	(P) → (2), (Q) → (5), (R) → (3), (S) → (4)
(B)	(P) → (5), (Q) → (3), (R) → (2), (S) → (4)
(C)	(P) → (5), (Q) → (4), (R) → (1), (S) → (3)
(D)	(P) → (4), (Q) → (3), (R) → (2), (S) → (5)

**Answer Q14: B**

Q.15

For real numbers  $\alpha, \beta, \gamma, \delta$  and  $\mu$ , consider the matrix

$$M = \begin{bmatrix} \alpha & \frac{1}{\sqrt{2}} & -\frac{1}{\sqrt{2}} \\ \frac{1}{\sqrt{3}} & \beta & \frac{1}{\sqrt{3}} \\ \gamma & \delta & \mu \end{bmatrix}.$$

Suppose that  $MM^T = I$ , where  $M^T$  is the transpose of the matrix  $M$ , and  $I$  is the  $3 \times 3$  identity matrix. Let

$$\vec{u} = \alpha \hat{i} + \frac{1}{\sqrt{3}} \hat{j} + \gamma \hat{k}, \quad \vec{v} = \frac{1}{\sqrt{2}} \hat{i} + \beta \hat{j} + \delta \hat{k} \quad \text{and} \quad \vec{w} = -\frac{1}{\sqrt{2}} \hat{i} + \frac{1}{\sqrt{3}} \hat{j} + \mu \hat{k}.$$

Match each entry in List-I to the correct entry in List-II and choose the correct option.

**List-I****List-II**(P) The value of  $\gamma^2 + \delta^2$  is

(1) 0

(Q) If  $x\vec{u} + y\vec{v} + z\vec{w} = \hat{j}$  for some real numbers  $x, y$  and  $z$ , then the value of  $x$  is

(2) 1

(R) The value of  $|\vec{u} \cdot (\vec{v} \times \vec{w})|$  is(3)  $\frac{1}{\sqrt{2}}$ (S) The value of  $|\vec{u} \times (\vec{v} \times \vec{w})|$  is(4)  $\frac{1}{\sqrt{3}}$ (5)  $\frac{5}{6}$ 

(A)	(P) $\rightarrow$ (5), (Q) $\rightarrow$ (4), (R) $\rightarrow$ (2), (S) $\rightarrow$ (1)
(B)	(P) $\rightarrow$ (4), (Q) $\rightarrow$ (5), (R) $\rightarrow$ (1), (S) $\rightarrow$ (2)
(C)	(P) $\rightarrow$ (5), (Q) $\rightarrow$ (3), (R) $\rightarrow$ (2), (S) $\rightarrow$ (1)
(D)	(P) $\rightarrow$ (5), (Q) $\rightarrow$ (4), (R) $\rightarrow$ (1), (S) $\rightarrow$ (2)

**Answer Q15: A**

Q.16

Match each entry in List-I to the correct entry in List-II and choose the correct option.

**List-I****List-II**

- |   |                                |
|---|--------------------------------|
| (P) The circle with centre $(1, 2)$ and touching the straight line $3x + 4y = 1$ , passes through   | (1) the point $(1, 1)$         |
| (Q) The common tangent to the circle $x^2 + y^2 = 2$ and the parabola $y^2 = 8x$ with positive slope, passes through  | (2) the point $(7, 9)$         |
| (R) Let $M$ be the end point of the latus rectum of the ellipse $3x^2 + 4y^2 = 48$ such that $M$ lies in the first quadrant. Then the normal to the ellipse drawn at $M$ passes through | (3) the point $(3, 2)$         |
| (S) Let $H$ be the hyperbola whose centre is at the origin, one of the foci is at $(5, 0)$ , and one directrix is $5x + 16 = 0$ . Then $H$ passes through                               | (4) the point $(2, 5)$         |
|   | (5) the point $(8, 3\sqrt{3})$ |

(A)	(P) $\rightarrow$ (3), (Q) $\rightarrow$ (4), (R) $\rightarrow$ (1), (S) $\rightarrow$ (2)
(B)	(P) $\rightarrow$ (3), (Q) $\rightarrow$ (2), (R) $\rightarrow$ (1), (S) $\rightarrow$ (5)
(C)	(P) $\rightarrow$ (3), (Q) $\rightarrow$ (2), (R) $\rightarrow$ (4), (S) $\rightarrow$ (5)
(D)	(P) $\rightarrow$ (4), (Q) $\rightarrow$ (1), (R) $\rightarrow$ (2), (S) $\rightarrow$ (3)

**Answer Q16: B**

**SECTION 1 (Maximum Marks:12)**

- This section contains **Four (04)** questions.
- Each question has **FOUR** options (A), (B), (C) and (D). **ONLY ONE** of these four options is the correct answer.
- For each question, choose the option corresponding to the correct answer.
- Answer to each question will be evaluated **according to the following marking scheme:**  
*Full Marks* : +3 If **ONLY** the correct option is chosen;  
*Zero Marks* : 0 If none of the options is chosen (i.e. the question is unanswered);  
*Negative Marks* : -1 In all other cases.

- Q.1 Consider a large disk of radius  $R$  and two smaller disks, each of radius  $r = R/50$ , lying on its circumference, as shown in the figure. The smaller disks are initially in contact with each other, with an angular separation  $\Delta\theta$  between their centers. They are made to roll without slipping in opposite directions, with constant angular velocities  $\omega$  and  $2\omega$  while the large disk is held stationary. The time  $\tau$  at which the smaller disks are again in contact is:  
 [Use  $\sin(\Delta\theta) = \Delta\theta$  and ignore gravity.]

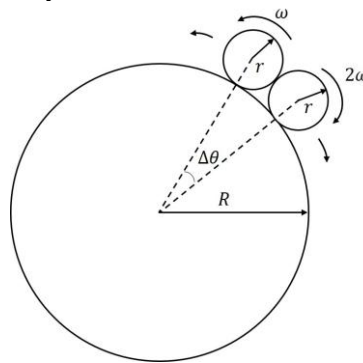

(A)	$\tau = 51 \times \left(2\pi - \frac{4}{51}\right) / \omega$	(B)	$\tau = 51 \times \left(2\pi - \frac{2}{51}\right) / 3\omega$
(C)	$\tau = 51 \times \left(2\pi - \frac{4}{51}\right) / 3\omega$	(D)	$\tau = 51 \times \left(2\pi - \frac{2}{51}\right) / \omega$

**Answer Q1: C**

Q.2 Consider a circuit consisting of a capacitor of capacitance  $C$  and a coil with  $N$  turns per unit length, cross sectional area  $S$  and length  $d$ , where  $d^2 \gg S$ . There is another coil of length  $d/2$ , cross sectional area  $S/2$  and  $2N$  turns per unit length completely inside the larger coil, as shown in the figure. The ends of this smaller coil are connected with each other by an insulated conducting wire. The self-inductance of the larger coil is  $L$ . Neglecting edge effects and all the Ohmic resistances, the resonant frequency of the circuit is:

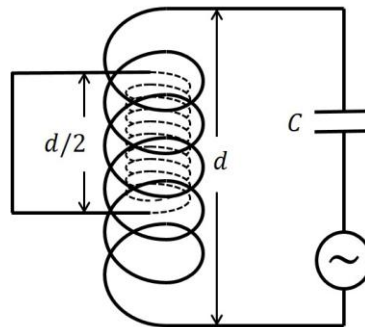

(A)	$\frac{4}{\sqrt{15 LC}}$	(B)	$\frac{6}{\sqrt{5 LC}}$	(C)	$\frac{2}{\sqrt{3 LC}}$	(D)	$\sqrt{\frac{2}{3 LC}}$
-----	--------------------------	-----	-------------------------	-----	-------------------------	-----	-------------------------

Answer Q2: C

Q.3 A solid cylinder of radius  $R$  rolls without slipping with a center of mass speed  $v_0 = \sqrt{\frac{gR}{3}}$  on a horizontal surface with a vertical edge, as shown in the figure. Here,  $g$  is the acceleration due to the gravity. At the moment when the cylinder loses contact with the surface due to rotation around the corner, the speed of its center of mass is:

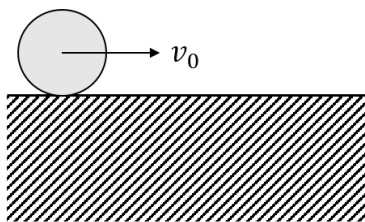

(A)	0	(B)	$\sqrt{\frac{5gR}{7}}$	(C)	$\sqrt{\frac{gR}{15}}$	(D)	$\sqrt{\frac{3gR}{7}}$
-----	---	-----	------------------------	-----	------------------------	-----	------------------------

Answer Q3: B

Q.4 A double convex lens made of glass of refractive index 1.5 and radii of curvature of the curved surfaces 20 cm each is immersed in a liquid of refractive index  $n_L$ . The correct plot showing the variation of the power, in the units of diopter ( $D$ ), as a function of  $n_L$  is:

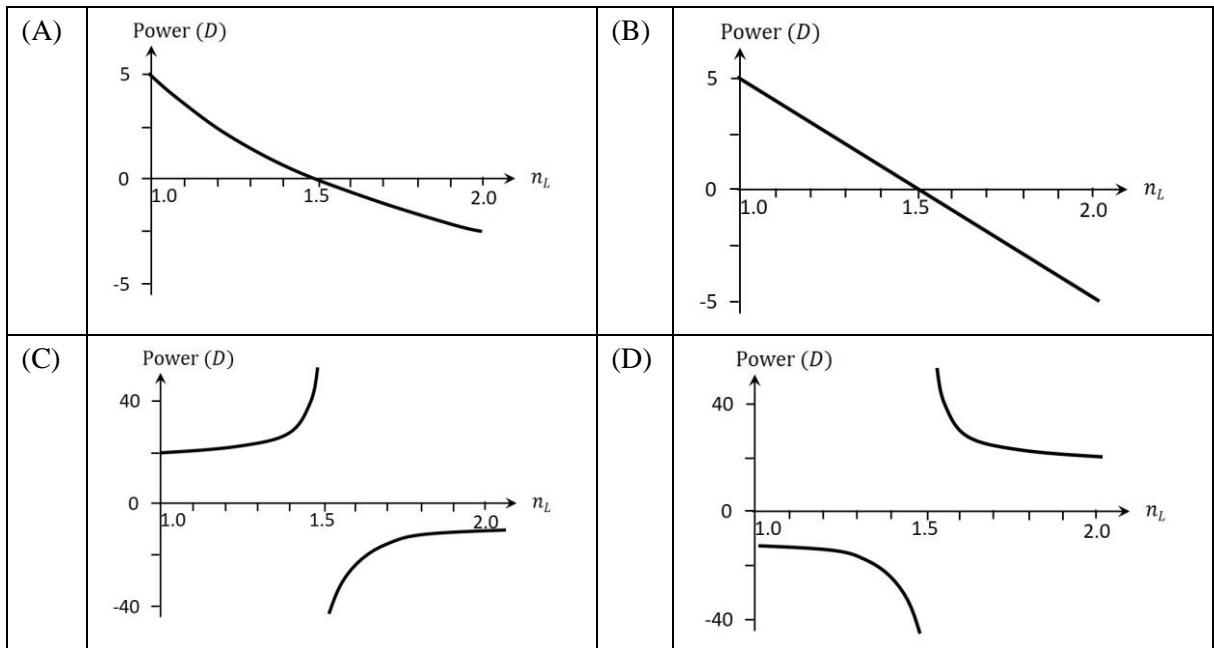

**Answer Q4: A or B**

**SECTION 2 (Maximum Marks:16)**

- This section contains **FOUR (04)** questions.
- Each question has **FOUR** options (A), (B), (C) and (D). **ONE OR MORE THAN ONE** of these four option(s) is(are) correct answer(s).
- For each question, choose the option(s) corresponding to (all) the correct answer(s).
- Answer to each question will be evaluated **according to the following marking scheme**:
 

*Full Marks* : +4 **ONLY** if (all) the correct option(s) is(are) chosen;

*Partial Marks* : +3 If all the four options are correct but **ONLY** three options are chosen;

*Partial Marks* : +2 If three or more options are correct but **ONLY** two options are chosen, both of which are correct;

*Partial Marks* : +1 If two or more options are correct but **ONLY** one option is chosen and it is a correct option;

*Zero Marks* : 0 If none of the options is chosen (i.e. the question is unanswered);

*Negative Marks* : -1 In all other cases.
- For example, in a question, if (A), (B) and (D) are the **ONLY** three options corresponding to correct answers, then
  - choosing **ONLY** (A), (B) and (D) will get +4 marks;
  - choosing **ONLY** (A) and (B) will get +2 marks;
  - choosing **ONLY** (A) and (D) will get +2 marks;
  - choosing **ONLY** (B) and (D) will get +2 marks;
  - choosing **ONLY** (A) will get +1 mark;
  - choosing **ONLY** (B) will get +1 mark;
  - choosing **ONLY** (D) will get +1 mark;
  - choosing no option (i.e. the question is unanswered) will get 0 marks; and
  - choosing any other combination of options will get -1 marks.

- Q.5 Consider a hydrogen atom with  $v_k, r_k,$  and  $K_k$  denoting the velocity, orbital radius and kinetic energy of the electron in the  $k^{\text{th}}$  orbit, respectively. The electron undergoes a transition from the  $n^{\text{th}}$  orbit, emitting radiation corresponding to the Lyman series. Considering  $h$  to be the Planck's constant and  $\epsilon_0$  the permittivity of the free space, the correct statement(s) is/are:

(A)	Magnitude of change in kinetic energy of electron can be expressed as $\frac{h}{4\pi} \left  \frac{nv_n}{r_n} - \frac{v_1}{r_1} \right $ .
(B)	Magnitude of change in de Broglie wavelength of the electron can be expressed as $\frac{e^2}{4\epsilon_0} \left  \frac{1}{K_n} - \frac{1}{K_1} \right $ .
(C)	Frequency of the radiation emitted can be expressed as $\frac{e^2}{8\pi\epsilon_0 h} \left( \frac{1}{r_1} - \frac{1}{r_n} \right)$ .
(D)	Magnitude of change in total energy of the electron can be expressed as $\frac{h}{2\pi} \left  \frac{v_1}{r_1} - \frac{nv_n}{r_n} \right $ .

**Answer Q5: AC**

- Q.6 A particle is thrown with a speed  $v$  from a point  $O$  at an angle  $\theta$  with the horizontal plane such that it passes through the point  $P$  at a height of 1 m and horizontal distance of 5 m from  $O$ , as shown in the figure. If acceleration due to gravity is  $g \text{ ms}^{-2}$ , then the correct statement(s) is/are:

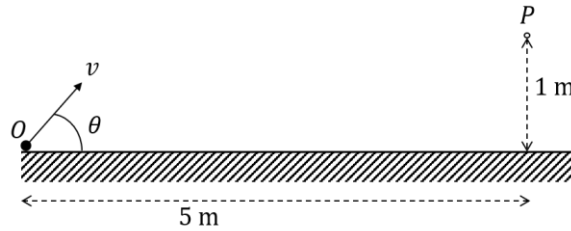

(A)	If $\theta = 45^\circ$ , then $v = \frac{5\sqrt{g}}{2} \text{ ms}^{-1}$ .
(B)	If $\theta = 45^\circ$ , the particle reaches its maximum height before it reaches $P$ .
(C)	If $\theta = 30^\circ$ , the particle reaches its maximum height after reaching $P$ .
(D)	If $\theta = \tan^{-1}\left(\frac{1}{5}\right)$ , then $v = 125\sqrt{g} \text{ ms}^{-1}$ .

**Answer Q6: AB**

- Q.7 A quasi-static cycle of a monoatomic ideal gas contains an isothermal process ( $ab$ ), followed by an isochoric process ( $bc$ ) and an adiabatic process ( $ca$ ) as shown in the figure. The volumes of the gas are  $V_1$  and  $V_2$  at  $a$  and  $b$ , respectively. If the cycle has heat input  $Q_{\text{in}}$  and output  $Q_{\text{out}}$ , then the efficiency of the cycle is defined as  $\eta = \frac{Q_{\text{in}} - Q_{\text{out}}}{Q_{\text{in}}}$ . The correct statement(s) is/are:

[Given:  $\ln 2 \approx 0.7$ ]

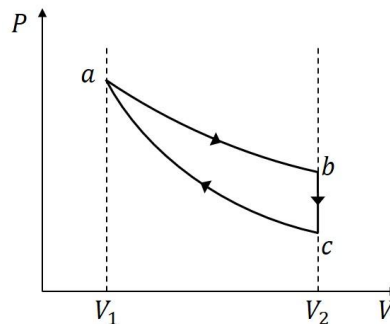

(A)	If $V_2/V_1 = 8$ , the heat released in the process $bc$ is smaller than the heat absorbed in the process $ab$ .
(B)	For a given value of $V_2/V_1$ , $\eta$ does not depend on the temperature of the isothermal process.
(C)	If $V_2/V_1 = 8$ , then the temperature of the gas at $a$ is 4 times the temperature of the gas at $c$ .
(D)	If $V_2/V_1 = 8$ , then the pressure of the gas at $a$ is 4 times the pressure of the gas at $b$ .

**Answer Q7: ABC**

Q.8

The electric field associated with an electromagnetic wave travelling in vacuum is given by  $E_0 \sin(3y + 4z + \omega t)\hat{i}$ , where  $\omega$  is the angular frequency. All quantities are in SI units. The correct statement(s) about this wave is/are:

[Given: speed of light in vacuum  $c = 3 \times 10^8 \text{ ms}^{-1}$ .]

(A)	The wave is travelling in $-\frac{1}{5}(3\hat{j} + 4\hat{k})$ direction.
(B)	The magnitude of the wave vector is $0.5 \text{ m}^{-1}$ .
(C)	The value of $\omega$ is $1.5 \times 10^9 \text{ rad s}^{-1}$ .
(D)	The magnetic field associated with this wave is given by $\frac{E_0}{c} \sin(3y + 4z + \omega t)(4\hat{j} - 3\hat{k})$ .

**Answer Q8: AC**

## SECTION 3 (Maximum Marks:16)

- This section contains **Four (04)** questions.
- The answer to each question is a **NUMERICAL VALUE**.
- For each question, enter the correct numerical value corresponding to the answer in the designated place using the mouse and the on-screen virtual numeric keypad.
- If the numerical value has more than two decimal places, **truncate/round-off** the value to **TWO** decimal places.
- Answer to each question will be evaluated **according to the following marking scheme**:  
*Full Marks* : +4 If **ONLY** the correct numerical value is entered in the designated place;  
*Zero Marks* : 0 In all other cases.

- Q.9 A tank contains two immiscible liquids of densities  $6\rho$  and  $2\rho$ . The higher density liquid is filled up to a height  $L/2$  from the bottom. A thin rod of density  $\rho$  and length  $L$  is fully immersed and hinged at the bottom so that it can oscillate freely, as shown in the figure. If the rod is slightly disturbed from its equilibrium, the time period of small oscillations is  $\frac{2\pi}{n} \sqrt{\frac{L}{g}}$ , where  $g$  is the acceleration due to gravity. The value of  $n$  is:

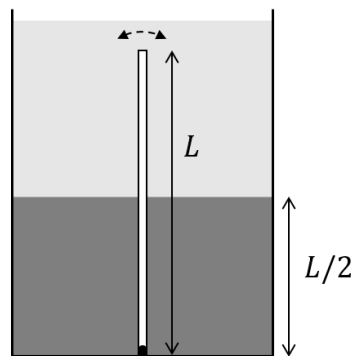

**Answer Q9: [1.70 to 1.75]**

- Q.10 As shown in the figure, five Carnot engines, each with efficiency  $\eta$  and same number of cycles per unit time, are operating between six heat reservoirs. The amount of heat released per cycle by one engine is completely absorbed by the next engine. Consider  $Q_0$  to be the amount of heat absorbed per cycle by the first engine and  $W$  as the amount of total work done by all the engines per cycle, then the net efficiency of the system is found to be  $\eta_{\text{net}} = \frac{W}{Q_0} = \frac{211}{243}$ . The value of  $\eta$  is:

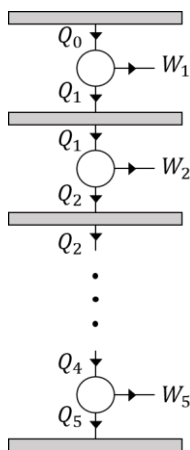

**Answer Q10: [0.32 to 0.34]**

- Q.11 As shown in the figure, an insulated container is fitted with a thermally conducting but immovable partition ( $P_1$ ) and a freely movable but thermally insulated piston ( $P_2$ ). The partition  $P_1$  with thermal conductivity  $K$ , cross sectional area  $A$  and width  $x$  divides the container into two sections,  $S_1$  and  $S_2$ , each containing one mole of a monoatomic gas. The piston  $P_2$  moves freely such that the gas in  $S_2$  is always at the atmospheric pressure. Initially, the difference between the temperatures of  $S_1$  and  $S_2$  is  $\Delta T_0$ . The time it takes for the temperature difference to become  $\frac{\Delta T_0}{2}$  is  $n\pi R/K A$ , where  $R$  is the universal gas constant. The value of  $n$  is:  
 [ Given:  $\ln 2 \approx 0.7$  ]

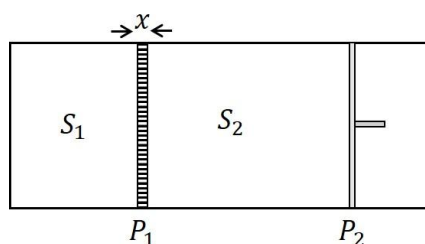

**Answer Q11: [0.63 to 0.68]**

- Q.12 A hollow, right circular cone of base radius  $R$  and height  $h$ , with its tip at the origin is rotating about the  $Z$ -axis with an angular velocity  $\omega$ , as shown in the figure. The cone carries a total charge  $Q$  uniformly distributed on its curved surface. The magnitude of magnetic field at a point  $(0,0,z)$ , where  $z \gg R$  and  $z \gg h$ , is  $\frac{n\mu_0 QR^2\omega}{4\pi z^3}$ . The value of  $n$  is:

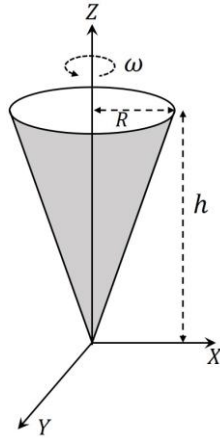

**Answer Q12: [0.50]**

**SECTION 4 (Maximum Marks:16)**

- This section contains **Four (04)** Matching List Sets.
- Each set has **ONE** Multiple Choice Question.
- Each set has **TWO** lists: **List-I** and **List-II**.
- **List-I** has **Four** entries (P), (Q), (R) and (S) and **List-II** has **Five** entries (1), (2), (3), (4) and (5).
- **FOUR** options are given in each Multiple Choice Question based on **List-I** and **List-II** and **ONLY ONE** of these four options satisfies the condition asked in the Multiple Choice Question.
- Answer to each question will be evaluated **according to the following marking scheme:**
  - Full Marks* : +4 **ONLY** if the option corresponding to the correct combination is chosen;
  - Zero Marks* : 0 If none of the options is chosen (i.e. the question is unanswered);
  - Negative Marks* : -1 In all other cases.

Q.13

**List-I** shows four configurations made of straight and semi-circular narrow tubes containing air. A sound wave of wavelength  $\lambda = 0.29$  m enters these structures at the point  $S$  and a sound detector is placed at  $D$ . Between the points  $S$  and  $D$ , the sound travels only through the tubes. **List-II** contains the possible smallest values of  $l$  (refer to the figures) for which the detector  $D$  records maximum amplitude. Ignore effects of sharp corners. [Given  $\cos(15^\circ) = 0.97$ ]

Choose the option that best describes the match between the entries in **List-I** to those in **List-II**.

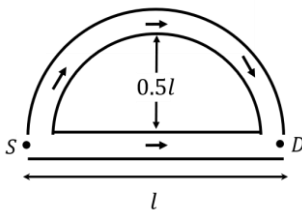
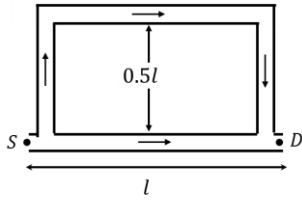
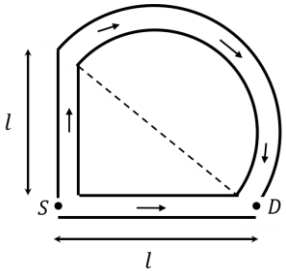
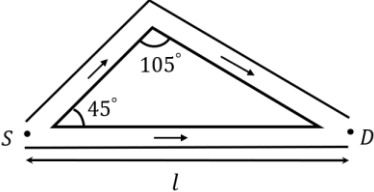
<b>List-I</b>	<b>List-II</b>
<p>(P) </p>	<p>(1) 1.32 m</p>
<p>(Q) </p>	<p>(2) 1.19 m</p>
<p>(R) </p>	<p>(3) 0.51 m</p>
<p>(S) </p>	<p>(4) 0.29 m</p> <p>(5) 0.13 m</p>

(A) P→4, Q→3, R→5, S→1	(B) P→4, Q→3, R→1, S→5
(C) P→3, Q→4, R→1, S→2	(D) P→3, Q→4, R→5, S→2

**Answer Q13: D**

Q.14

In the **List-I**, four optical effects are mentioned. The physical phenomena of light which are essential to describe these optical effects are given in **List-II**. Choose the option which describes the correct match between the entries in **List-I** to those in **List-II**.

**List-I**

(P) Colorful sky in north polar region (Aurora Borealis)

(Q) Partially polarized sun light

(R) Rainbow

(S) Dark and bright fringes

**List-II**

(1) Dispersion and reflection

(2) Total internal reflection

(3) Diffraction

(4) Scattering of light by molecules in the atmosphere

(5) Emission of radiation from oxygen and nitrogen atoms excited by charged particles

(A)	P→5, Q→4, R→1, S→3	(B)	P→4, Q→2, R→1, S→3
(C)	P→4, Q→1, R→2, S→3	(D)	P→5, Q→4, R→1, S→2

**Answer Q14: A**

**Q.15** **List-I** contains four conducting loops lying in the  $XY$  plane, as shown in the figures. The loops are rotating about  $Z$  axis passing through the point  $O$  with time period  $T$  in clockwise direction. The region  $x > 0$  contains a uniform magnetic field  $B$  in the  $+z$  direction. **List-II** contains the qualitative variation of the induced current  $i(t)$  for each of these loops. Choose the option which describes the correct match between the entries in **List-I** to those in **List-II**.

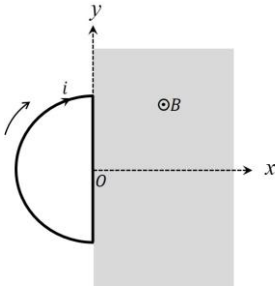
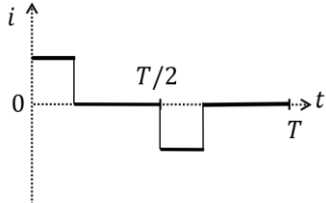
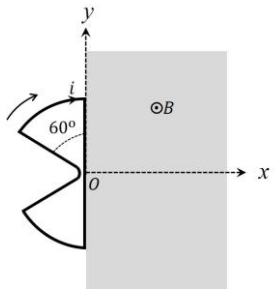
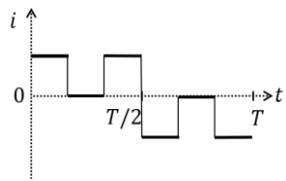
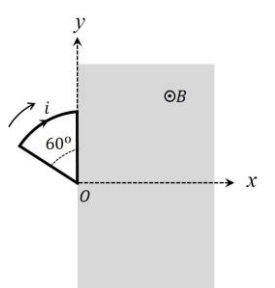
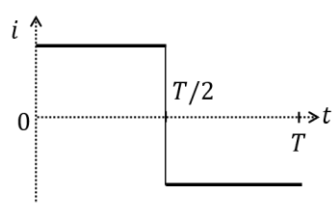
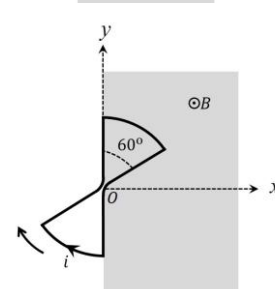
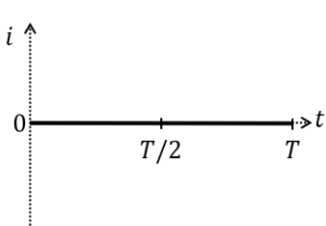
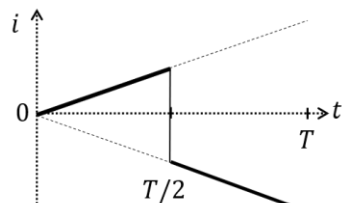
<b>List-I</b>	<b>List-II</b>
<p>(P) </p>	<p>(1) </p>
<p>(Q) </p>	<p>(2) </p>
<p>(R) </p>	<p>(3) </p>
<p>(S) </p>	<p>(4) </p>
	<p>(5) </p>

(A) P → 5, Q → 4, R → 1, S → 3	(B) P → 3, Q → 2, R → 5, S → 4
(C) P → 3, Q → 2, R → 1, S → 4	(D) P → 5, Q → 1, R → 2, S → 3

**Answer Q15: C**

Q.16

**List-I** shows four planar structures made of uniform solid rods each of mass  $m$  and length  $l$ . In the **List-II** the possible moment of inertia of these structures about an axis  $OCO'$ , which lies in the plane of the structures, are given.

Choose the option that describes the correct match between the entries in **List-I** to those in **List-II**.

**List-I**

**List-II**

(P)

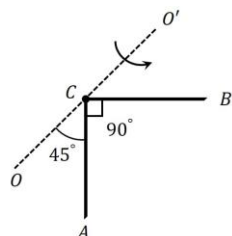

(1)  $\frac{5}{4}ml^2$

(Q)

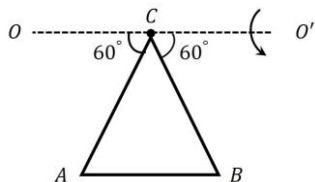

(2)  $\frac{1}{6}ml^2$

(R)

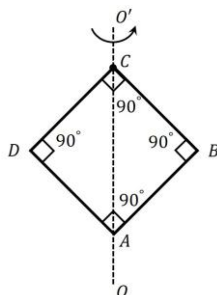

(3)  $\frac{1}{12}ml^2$

(S)

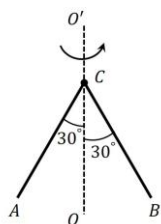

(4)  $\frac{2}{3}ml^2$

(5)  $\frac{1}{3}ml^2$

(A)	P → 5, Q → 1, R → 4, S → 2	(B)	P → 1, Q → 3, R → 4, S → 2
(C)	P → 5, Q → 3, R → 2, S → 1	(D)	P → 5, Q → 4, R → 2, S → 1

**Answer Q16: A**

## SECTION 1 (Maximum Marks: 12)

- This section contains **FOUR (04)** questions.
- Each question has **FOUR** options (A), (B), (C) and (D). **ONLY ONE** of these four options is the correct answer.
- For each question, choose the option corresponding to the correct answer.
- Answer to each question will be evaluated **according to the following marking scheme**:  
*Full Marks* : +3 If **ONLY** the correct option is chosen;  
*Zero Marks* : 0 If none of the options is chosen (i.e. the question is unanswered);  
*Negative Marks* : -1 In all other cases.

- Q.1 An ideal gas (0.5 mol), initially at 2 bar pressure, is compressed at a constant temperature of 600 K in two steps: first, against a constant external pressure of  $P$  bar ( $2 < P < 8$ ), and then against constant external pressure of 8 bar. At each step, the compression is stopped only when the pressure of the gas becomes equal to the external pressure. The total work done on the gas in these steps is  $W$ . Considering all possible values of  $P$  ( $2 < P < 8$ ) and taking the gas constant as  $R$  (in  $\text{J K}^{-1} \text{mol}^{-1}$ ), the minimum value of  $|W|$  (in J) is

(A)	$207R$	(B)	$600R$	(C)	$630R$	(D)	$900R$
-----	--------	-----	--------	-----	--------	-----	--------

Answer Q1: B

- Q.2 For a reversible reaction  $\text{R} \rightleftharpoons \text{P}$ , at constant temperature, both the forward and the backward reactions are first order elementary reactions with rate constants  $k_f$  and  $k_b$ , respectively. At time zero, the concentration of  $\text{R}$  is  $[\text{R}]_0$  and the concentration of  $\text{P}$  is zero. At any given time,  $[\text{R}]$  and  $[\text{P}]$  are the concentrations of  $\text{R}$  and  $\text{P}$ , respectively. If  $k_b = 4k_f$ , the correct graphical representation of the reaction is

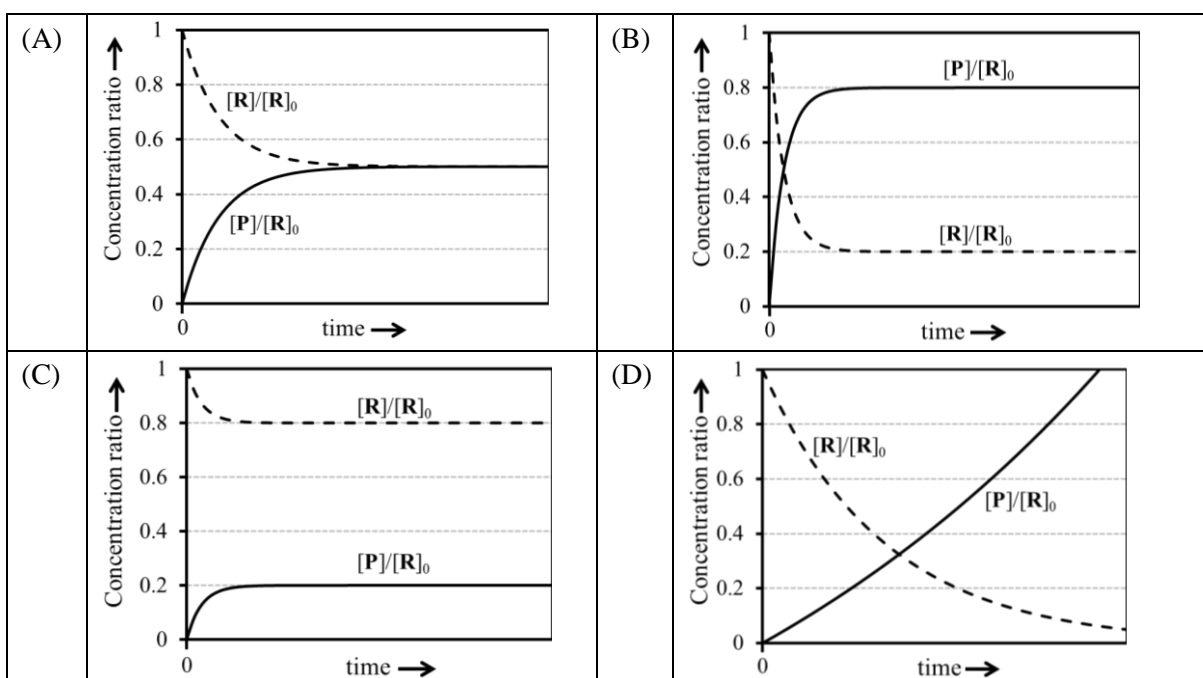

Answer Q2: C

Q.3 The correct order of dipole moments for the given species is

- |     |   |
|-----|---|
| (A) | $\text{BF}_3 = \text{NH}_4^+ < \text{NF}_3 < \text{NH}_3$ |
| (B) | $\text{BF}_3 < \text{NH}_4^+ < \text{NF}_3 < \text{NH}_3$ |
| (C) | $\text{NH}_4^+ < \text{BF}_3 < \text{NH}_3 < \text{NF}_3$ |
| (D) | $\text{BF}_3 < \text{NH}_4^+ < \text{NH}_3 < \text{NF}_3$ |

Answer Q3: A

Q.4 Considering  $\text{LiBH}_4$  reduces an ester group to the corresponding alcohol and does not reduce a carboxylic acid group, the correct statement about the major products **P**, **Q**, **R** and **S** is

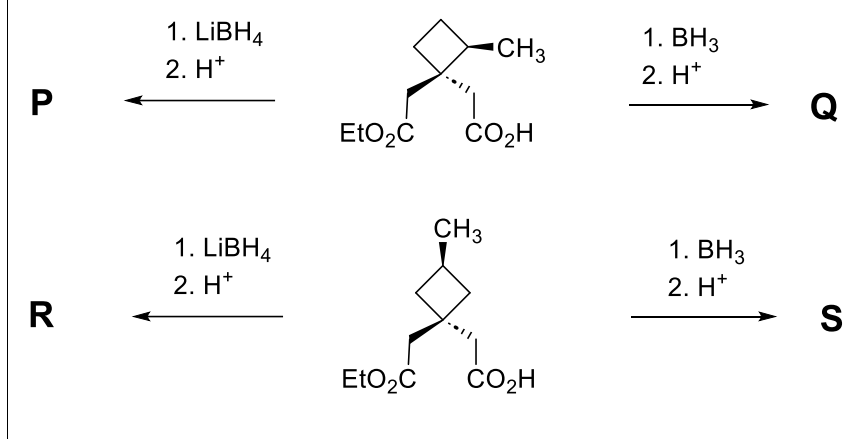

- |     |   |
|-----|---|
| (A) | <b>P</b> & <b>Q</b> are identical, and <b>R</b> & <b>S</b> are diastereomers.     |
| (B) | <b>P</b> & <b>Q</b> are diastereomers, and <b>R</b> & <b>S</b> are identical.     |
| (C) | <b>P</b> & <b>Q</b> are diastereomers, and <b>R</b> & <b>S</b> are diastereomers. |
| (D) | <b>P</b> & <b>Q</b> are identical, and <b>R</b> & <b>S</b> are identical.         |

Answer Q4: C

**SECTION 2 (Maximum Marks: 16)**

- This section contains **FOUR (04)** questions.
- Each question has **FOUR** options (A), (B), (C) and (D). **ONE OR MORE THAN ONE** of these four option(s) is(are) correct answer(s).
- For each question, choose the option(s) corresponding to (all) the correct answer(s).
- Answer to each question will be evaluated **according to the following marking scheme:**

*Full Marks* : +4 **ONLY** if (all) the correct option(s) is(are) chosen;

*Partial Marks* : +3 If all the four options are correct but **ONLY** three options are chosen;

*Partial Marks* : +2 If three or more options are correct but **ONLY** two options are chosen, both of which are correct;

*Partial Marks* : +1 If two or more options are correct but **ONLY** one option is chosen and it is a correct option;

*Zero Marks* : 0 If none of the options is chosen (i.e. the question is unanswered);

*Negative Marks* : -1 In all other cases.
- For example, in a question, if (A), (B) and (D) are the **ONLY** three options corresponding to correct answers, then
  - choosing **ONLY** (A), (B) and (D) will get +4 marks;
  - choosing **ONLY** (A) and (B) will get +2 marks;
  - choosing **ONLY** (A) and (D) will get +2 marks;
  - choosing **ONLY** (B) and (D) will get +2 marks;
  - choosing **ONLY** (A) will get +1 mark;
  - choosing **ONLY** (B) will get +1 mark;
  - choosing **ONLY** (D) will get +1 mark;
  - choosing no option (i.e. the question is unanswered) will get 0 marks; and
  - choosing any other combination of options will get -1 marks.

- Q.5 The 2s and the 2p orbital energies of hydrogen atom are  $E_{2s}(\text{H})$  and  $E_{2p}(\text{H})$ , respectively. The 2s and the 2p orbital energies of lithium atom are  $E_{2s}(\text{Li})$  and  $E_{2p}(\text{Li})$ , respectively. The correct option(s) about the orbital energies is(are)

(A)	$E_{2s}(\text{Li}) < E_{2p}(\text{Li})$
(B)	$E_{2s}(\text{H}) = E_{2p}(\text{H})$
(C)	$E_{2p}(\text{H}) < E_{2s}(\text{Li})$
(D)	$E_{2s}(\text{H}) > E_{2s}(\text{Li})$

**Answer Q5: ABD**

Q.6 Correct statement(s) about the compounds **X**, **Y** and **Z** is(are)

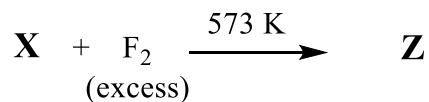
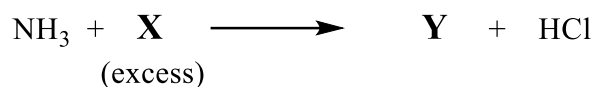
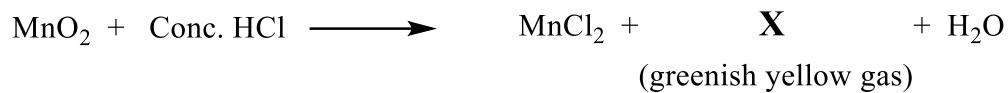

(A)	<b>X</b> is used for sterilizing drinking water.
(B)	<b>Y</b> has a planar structure.
(C)	<b>Z</b> is used in the enrichment of $^{235}\text{U}$ .
(D)	<b>Y</b> is a stronger Lewis base than ammonia.

**Answer Q6: AC**

Q.7 Reaction of  $\text{PtF}_6$  with oxygen ( $\text{O}_2$ ) gas results in the formation of an ionic compound,  $\text{X}^+\text{Y}^-$ .  
Correct statement(s) is(are)

(A)	The bond order of $\text{X}^+$ is 1.5.
(B)	Valence <i>d</i> -orbitals of the metal ion in $\text{X}^+\text{Y}^-$ has 5 electrons.
(C)	$\text{PtF}_6$ acts as an oxidant in this reaction.
(D)	$\text{PtF}_6$ acts as a fluorinating agent in this reaction.

**Answer Q7: BC**

Q.8 In the following reaction sequence, **Q**, **R**, **S** and **T** are the major products.

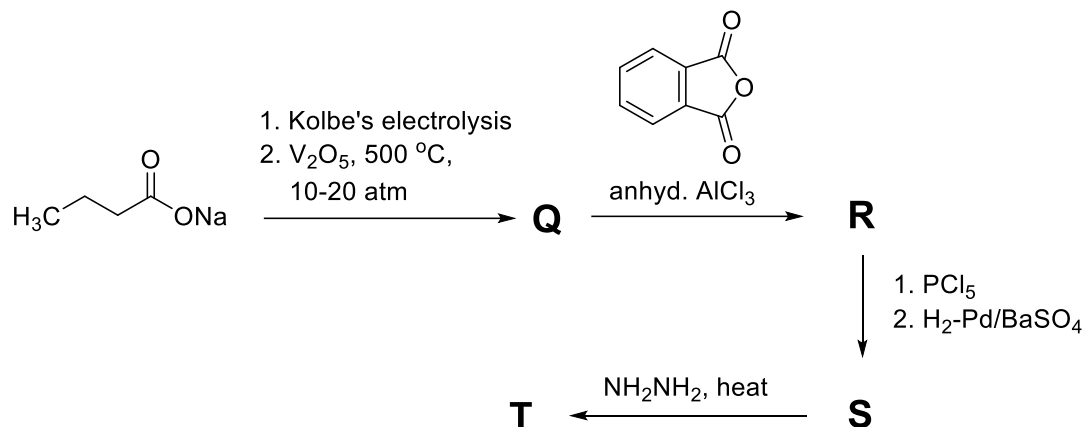

The correct statement(s) about **Q**, **R**, **S** and **T** is(are)

(A)	<b>S</b> on warming with ammoniacal $\text{AgNO}_3$ results in the formation of silver mirror.
(B)	<b>Q</b> on treatment with $\text{Cl}_2$ (excess)/UV gives gammmaxane.
(C)	<b>T</b> is a heterocyclic compound.
(D)	<b>R</b> on acid catalyzed intramolecular cyclization followed by treatment with $\text{Zn-Hg/HCl}$ gives 9,10-dihydroxyanthracene.

**Answer Q8: ABC**

## SECTION 3 (Maximum Marks: 16)

- This section contains **FOUR (04)** questions.
- The answer to each question is a **NUMERICAL VALUE**.
- For each question, enter the correct numerical value corresponding to the answer in the designated place using the mouse and the on-screen virtual numeric keypad.
- If the numerical value has more than two decimal places, **truncate/round-off** the value to **TWO** decimal places.
- Answer to each question will be evaluated **according to the following marking scheme**:  
*Full Marks* : +4 If ONLY the correct numerical value is entered in the designated place;  
*Zero Marks* : 0 In all other cases.

- Q.9 Two cylinders, both fitted with frictionless pistons, are filled with mixtures of He and Ar gases. In the first cylinder, the masses of He and Ar are  $m_1$  and  $m_2$ , respectively. In the second cylinder, the masses of He and Ar are  $m_2$  and  $m_1$ , respectively. The molar mass of Ar is 10 times the molar mass of He. The external pressure applied by the piston on the first cylinder needs to be 5 times that on the second cylinder so that the volume of the gas mixtures in both the cylinders are equal at the same temperature. Assuming He and Ar behave like ideal gases, the value of  $(m_1/m_2)$  is \_\_\_\_.

**Answer Q9: [9.80]**

- Q.10 The total number of all possible isomers for the square planar complex with formula  $K[M(NCS)(NO_2)(gly)]$  is \_\_\_\_.
- (M = metal ion and gly =  $NH_2CH_2COO^-$ )

**Answer Q10: [8]**

- Q.11 The sum of total number of carbonyl groups ( $>C=O$ ) present in the major products **X** and **Y** in the following reactions is \_\_\_\_.

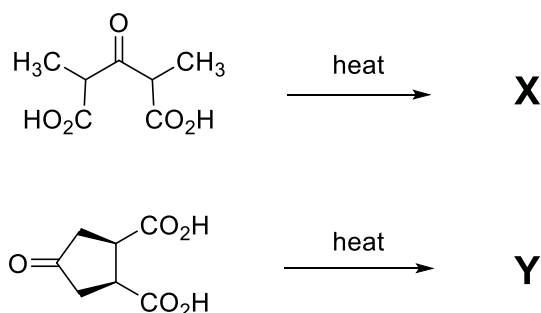

**Answer Q11: [4]**

- Q.12 Treatment of buta-1,3-diyne with  $NaNH_2$  (2 equivalents), followed by reaction with excess of *trans*- $CH_3-CH=CH-CH_2-Br$  gives **X** as the major product. The maximum number of carbon atoms that are collinear (in a straight line) in **X** is \_\_\_\_.

**Answer Q12: [6]**

**SECTION 4 (Maximum Marks: 16)**

- This section contains **FOUR (04)** Matching List Sets.
- Each set has **ONE** Multiple Choice Question.
- Each set has **TWO** lists: **List-I** and **List-II**.
- **List-I** has **Four** entries (P), (Q), (R) and (S) and **List-II** has **Five** entries (1), (2), (3), (4) and (5).
- **FOUR** options are given in each Multiple Choice Question based on **List-I** and **List-II** and **ONLY ONE** of these four options satisfies the condition asked in the Multiple Choice Question.
- Answer to each question will be evaluated **according to the following marking scheme:**  
*Full Marks* : +4 **ONLY** if the option corresponding to the correct combination is chosen;  
*Zero Marks* : 0 If none of the options is chosen (i.e. the question is unanswered);  
*Negative Marks* : -1 In all other cases.

- Q.13 **List-I** contains various physical/chemical processes, and **List-II** contains combinations of changes in enthalpy ( $\Delta H$ ) and entropy ( $\Delta S$ ). Match each entry in **List-I** to the appropriate entry in **List-II**, and choose the correct option.

**List-I**

(P) Physisorption

(Q) Diamond  $\rightarrow$  Graphite

(R) Denaturation of protein

(S) Propene  $\rightarrow$  Cyclopropane**List-II**(1)  $\Delta H > 0$  and  $\Delta S > 0$ (2)  $\Delta H < 0$  and  $\Delta S < 0$ (3)  $\Delta H < 0$  and  $\Delta S = 0$ (4)  $\Delta H > 0$  and  $\Delta S < 0$ (5)  $\Delta H < 0$  and  $\Delta S > 0$ 

(A)	P $\rightarrow$ 2; Q $\rightarrow$ 3; R $\rightarrow$ 5; S $\rightarrow$ 4
(B)	P $\rightarrow$ 4; Q $\rightarrow$ 3; R $\rightarrow$ 5; S $\rightarrow$ 1
(C)	P $\rightarrow$ 2; Q $\rightarrow$ 5; R $\rightarrow$ 1; S $\rightarrow$ 4
(D)	P $\rightarrow$ 2; Q $\rightarrow$ 5; R $\rightarrow$ 1; S $\rightarrow$ 3

**Answer Q13: C**

Q.14

Consider the following species:

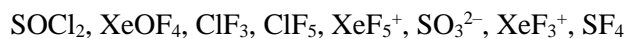

**List-I** contains different molecular shapes and **List-II** contains total number of species with the same molecular shapes from the given species. Match each entry in **List-I** with the appropriate entry in **List-II** and choose the correct option.

**List-I**

(P) See-saw

(Q) T-Shaped

(R) Trigonal Planar

(S) Square Pyramidal

**List-II**

(1) one

(2) two

(3) three

(4) four

(5) zero

(A)	P → 1; Q → 2; R → 5; S → 3
(B)	P → 5; Q → 4; R → 2; S → 3
(C)	P → 3; Q → 2; R → 1; S → 4
(D)	P → 1; Q → 3; R → 5; S → 4

**Answer Q14: A**

Q.15 The **List-II** contains products obtained from the reaction of compounds in **List-I** with  $O_3/Zn-H_2O$  followed by cyclization (via more stable enolate) in the presence of aqueous NaOH. Match each entry in **List-I** with appropriate entry in **List-II** and choose the correct option.

**List-I**

(P)

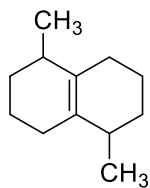

(Q)

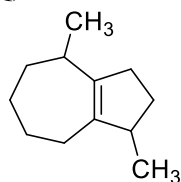

(R)

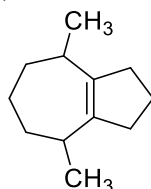

(S)

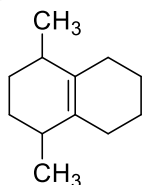
**List-II**

(1)

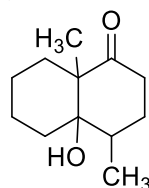

(2)

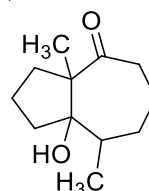

(3)

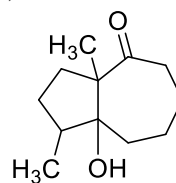

(4)

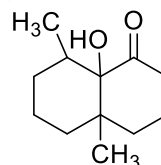

(5)

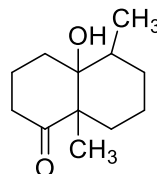

(A)	P → 2; Q → 4; R → 1; S → 3
(B)	P → 3; Q → 4; R → 5; S → 2
(C)	P → 2; Q → 1; R → 5; S → 3
(D)	P → 3; Q → 5; R → 4; S → 2

**Answer Q15: C**

Q.16 Match the major products obtained in the reactions given in **List-I** with the corresponding structures in **List-II** and choose the correct option.

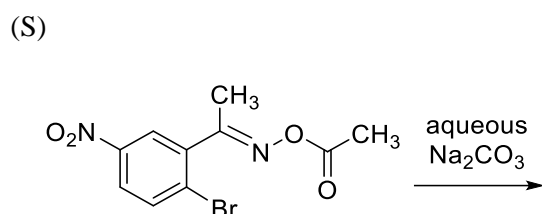
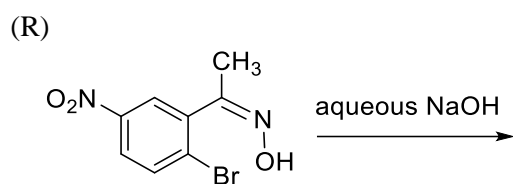
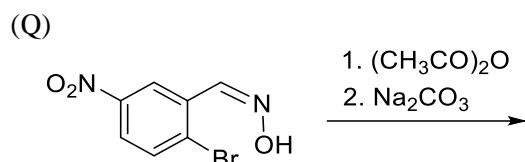
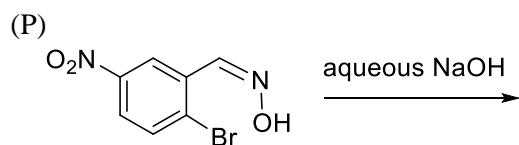
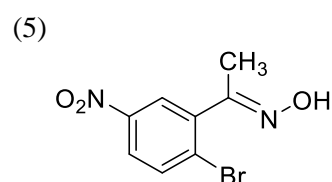
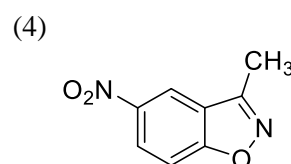
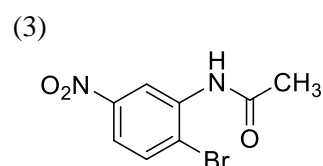
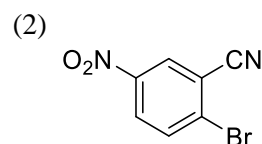
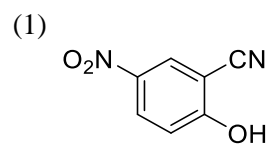
**List-I****List-II**

(A)	P $\rightarrow$ 2; Q $\rightarrow$ 1; R $\rightarrow$ 5; S $\rightarrow$ 4
(B)	P $\rightarrow$ 1; Q $\rightarrow$ 2; R $\rightarrow$ 4; S $\rightarrow$ 5
(C)	P $\rightarrow$ 1; Q $\rightarrow$ 2; R $\rightarrow$ 3; S $\rightarrow$ 4
(D)	P $\rightarrow$ 2; Q $\rightarrow$ 1; R $\rightarrow$ 3; S $\rightarrow$ 5

**Answer Q16: B**