

Time: 3 hours Maximum Marks: 300

READ THE INSTRUCTIONS CAREFULLY

GENERAL

- This sealed booklet is your Question Paper. Do not break the seal till you are told to do so.
- Immediately after breaking the seal of the booklet, verify that the booklet contains **32 pages** and that all the **16 questions** along with the options are legible. Report immediately about any missing or torn sheet in this booklet and ask for a replacement of the booklet from the invigilator. No replacement will be allowed after 15 minutes of the starting of the examination.
- Write your Name, Roll Number, JEE (Adv) 2021 Rank and other details in the space provided and nowhere else. No distinctive / identification mark of any type is to be put anywhere else in this booklet.
- Answers are to be written only in the booklet and within the space provided beside / below each Question and nowhere else. Answers written in non-designated place will not be evaluated.
- Blank spaces are provided within this booklet for rough work.
- Do not deface this booklet or detach or mutilate any sheet from the booklet. Such acts lead to disqualification.
- The question paper has five sections.
- **All the Questions are compulsory.**

Total Marks Obtained:

In Numbers:

In words: _____

Signature of the Examiner with date

Signature of the Scrutinizer with date

NAME: _____

ROLL NO: _____

JEE (ADV) 2021 RANK: _____

CATEGORY: _____

CATEGORY RANK (IF APPLICABLE):

EXAMINATION CENTRE:

I HAVE READ ALL THE INSTRUCTIONS AND SHALL ABIDE BY THEM

Signature of the Candidate

Signature of the Invigilator after verification of identity and other details

This Page is kept blank intentionally

DO NOT WRITE ON THIS PAGE

SECTION A: Architectural Awareness (Maximum Marks: 60)

This section contains **FOUR** questions. Question 1 carries **30 marks**, Questions 2, 3 and 4 carry **10 marks** each. There is **NO** negative marking.

Q.1. This section contains **15 multiple choice questions**. Each question has four options, out of which **ONLY ONE** is correct. Mark the correct option with a tick mark.

(15 x 2 = 30 Marks)

- (i) A wooden cube has its outer faces painted in three colours (Black, Gray and White). The pattern of coloring on surfaces is shown here using two different views of the same cube. If this cube is divided into 64 equal small cubes, how many small cubes will have only two faces coloured – one in black and one in gray.

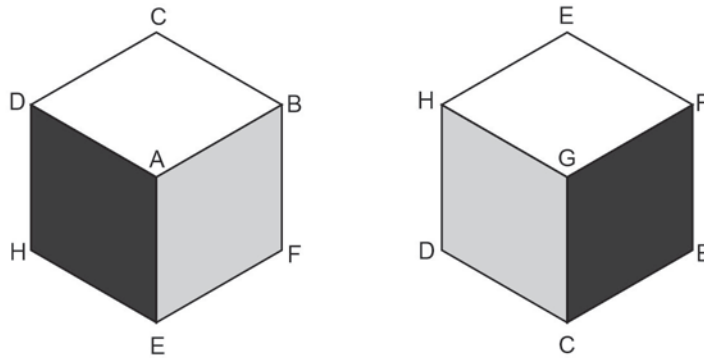

A 4

B 8

C 12

D 16

- (ii) Consider the four housing projects mentioned below. Select the option which indicates the projects that were undertaken by Charles Correa.

1: Tara Housing, Delhi

2: Sheikh Sarai Housing Complex, New Delhi

3: Aranya Community Housing, Indore

4: HUDCO Courtyard Housing, Jodhpur

A 1 and 2

B 2 and 3

C 1 and 4

D 3 and 4

(iii) A trabeated system consists of a simply supported horizontal member resting on two vertical members. Select the option that indicates structure/s that adopt/s this structural system.

1: Gopuram of Meenakshi Temple, Madurai

2: Temple of Athena, Athens

3: Aqueduct of Segovia

4: Hagia Sophia, Istanbul

A

Only 1

B

1 and 2

C

3 and 4

D

2 and 3

(iv) A square plate with a co-axial circular cutout is vertically rested on the horizontal plane (HP). The plate casts a shadow on the HP because of light coming at an angle of 30° to the HP, from behind the plate. The graphic representation of the same is shown below. If the length of the shadow on the HP is 9m, and the minor axis of the ellipse is $\sqrt{3.5}$ m, select the correct option indicating the area of the plate.

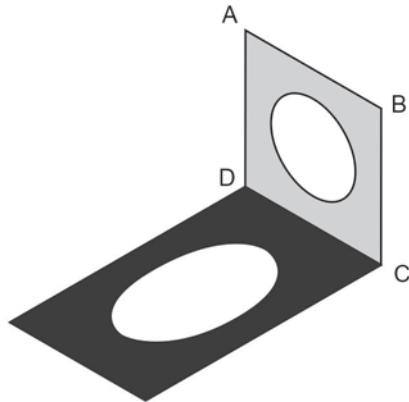

A

11 sqm

B

5.8 sqm

C

27 sqm

D

16 sqm

(v) The figure below represents the geometric relationship of various sizes of A-type sheets, all of which have a constant ratio of length: breadth. Select the closest representation of this ratio from the given options.

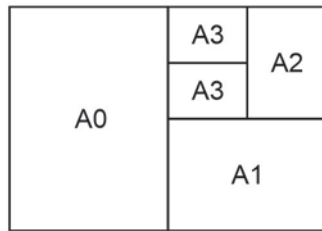

A 1.5

B $\sqrt{2}$

C $\pi/2$

D 1.618

(vi) Consider the 4 square grids given below. Pick the odd one out.

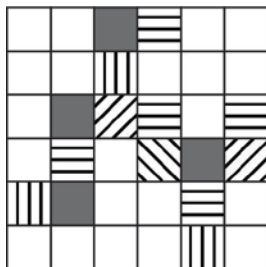

1

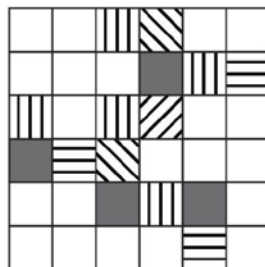

2

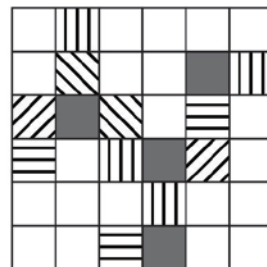

3

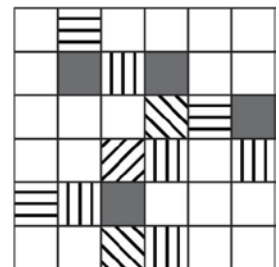

4

A 1

B 2

C 3

D 4

(vii) Consider the shapes of various interlocking tiles shown below. Which of these **CANNOT** be utilized to pave a flat surface without any interstitial spaces?

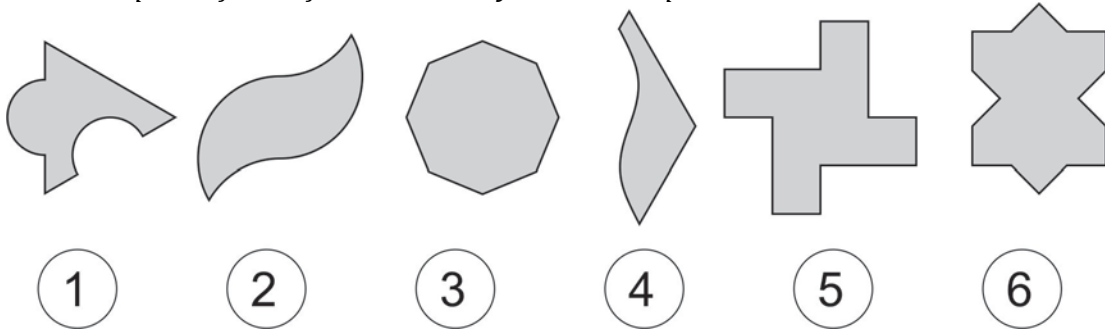

A 1, 2, 3, 4 and 5

B 4, 5 and 6

C 2 and 3

D 1, 3 and 4

(viii) Consider the two statements (*R* and *S*) given below and select the correct option.

Statement R: Padma Shri Bimal Patel is the architect of the Central Vista Redevelopment Plan, New Delhi.

Statement S: Padma Bhushan B. V. Doshi is the architect of the Statue of Unity, Kevadia.

A Statement R is true, but Statement S is false

B Statement R is false, but Statement S is true

C Both statements R and S are false

D Both statements R and S are true

- (ix) Consider the 12-step colour wheel given below. Select the correct option that represents the colours in a triadic colour scheme, where one of the colours is the complimentary colour to red.

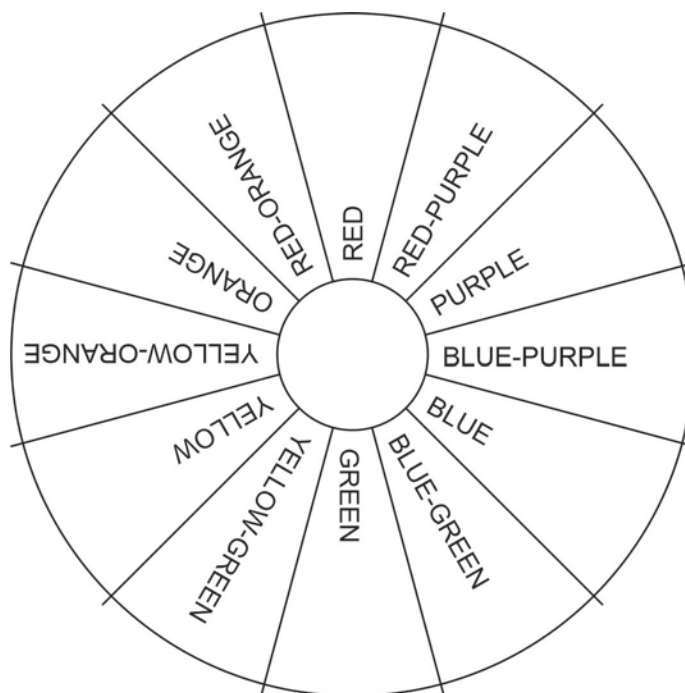

- A Blue, Red, Yellow
- B Yellow-Green, Yellow, Yellow-Orange
- C Green, Orange, Purple
- D Red, Red-Orange, Red-Purple

- (x) Consider the two statements (P and Q) given below and select the correct option.

Statement P: Reinforced Cement Concrete (RCC) is Plain Cement Concrete (PCC) with the addition of steel reinforcements, while PCC is a mixture of lime, sand and cement.

Statement Q: Steel is used to withstand compressive and tensile forces, while glass is used for withstanding only tensile forces.

- A Statement P is true, but Statement Q is false
- B Both Statements P and Q are partially true
- C Statement P is partially true, but Statement Q is false
- D Statement P is false, but Statement Q is partially true

(xi) '1' marks the centre-line of a cylinder of diameter x and length $>2x$.

'2' marks the centre-line of a sphere of diameter $2x$.

A new solid is created by merging the cylinder and the sphere in a manner that the centre-lines '1' and '2' coincide, and both the flat ends of the cylinder lie outside of the sphere. Select the correct figure (from options P, Q, R, S) that represents the elevation of the merged solid.

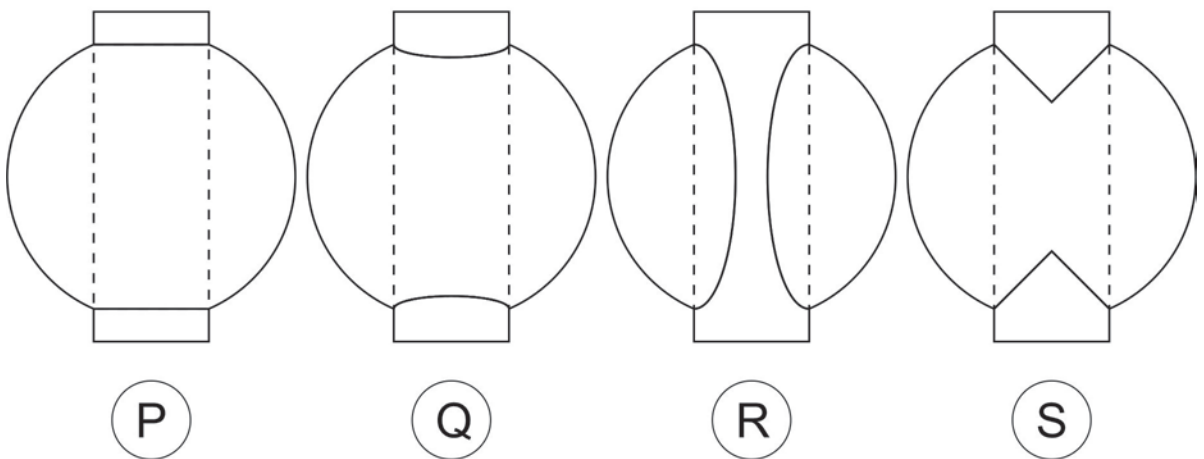
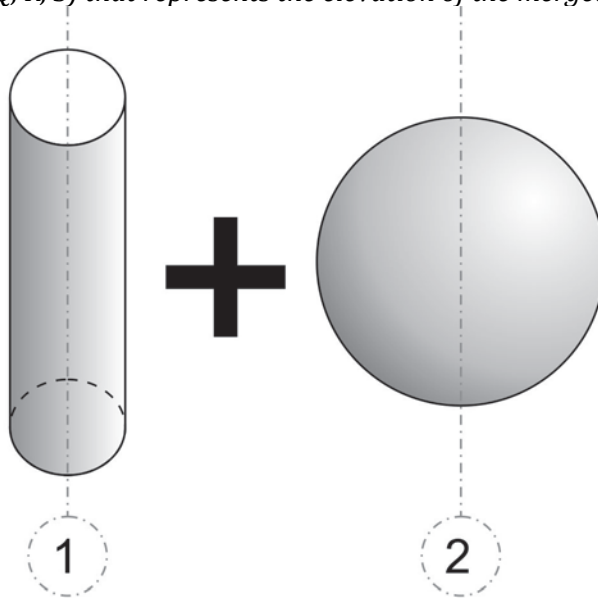

A P

B Q

C R

D S

(xii) Maharaja Sawai Jai Singh II had commissioned the construction of five astronomical observatories (Jantar Mantar), only four of which still exist. Two of these are located at Jaipur and Delhi. The other two existing ones are located at:





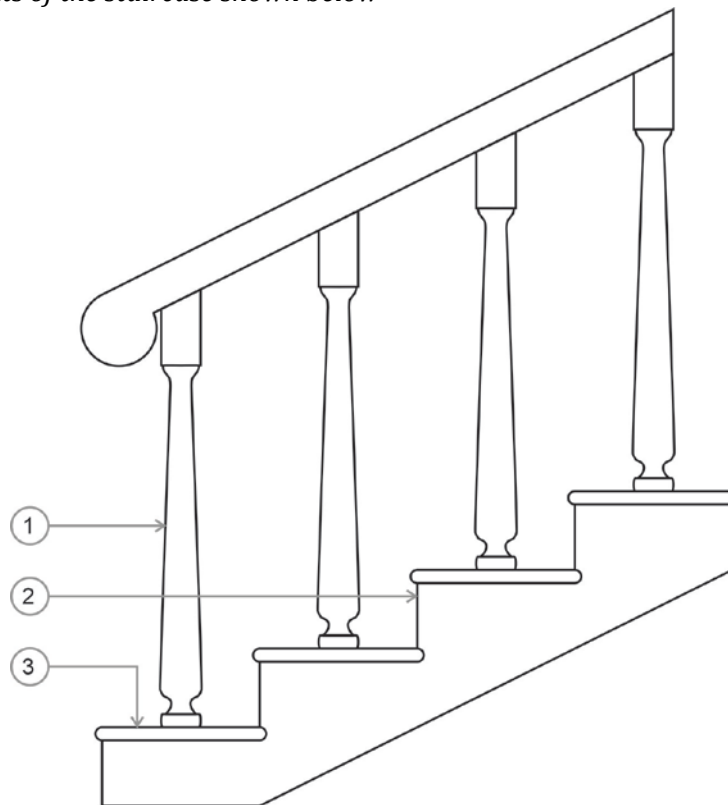



- A Ujjain and Agra
- B Mathura and Agra
- C Allahabad and Varanasi
- D Ujjain and Varanasi

(xiii) Identify the elements of the staircase shown below

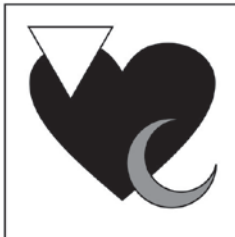



- A 1 is Tread, 2 is Baluster, 3 is Riser
- B 1 is Baluster, 2 is Riser, 3 is Tread
- C 1 is Riser, 2 is Tread, 3 is Baluster
- D 1 is Baluster, 2 is Tread, 3 is Riser

(xiv) Consider the compositions in Figures 1, 2, 3, and 4, and the graphic codes below each figure, which logically relates to the elements in these compositions. Using the same logic, select the correct graphic code for the composition in Figure 5.

			
FIGURE 1	FIGURE 2	FIGURE 3	FIGURE 4
			
			
FIGURE 5			

<p>A </p>	<p>B </p>
<p>C </p>	<p>D </p>

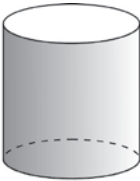
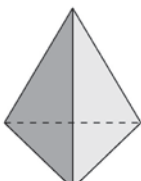
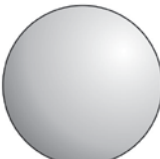
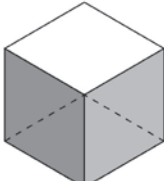

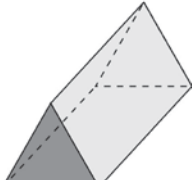
(xv) Considering the solids represented in Figures 1 to 6, select the sequence that has a logical order.

					
1	2	3	4	5	6

<p>A </p>	<p>B </p>
<p>C </p>	<p>D </p>



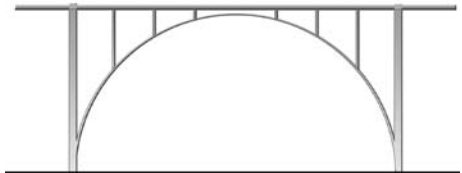
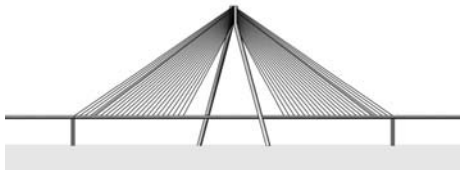

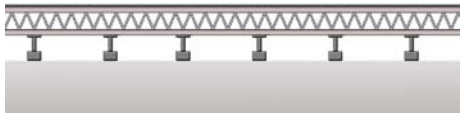
Q.2 Match the schematic figures of different bridges in Column I with their corresponding structural systems in Column II.

(5 x 2 = 10 Marks)

Column I	Column II
<p>(A) <input type="checkbox"/></p> 	<p>(P) Cable stayed</p>
<p>(B) <input type="checkbox"/></p> 	<p>(Q) Truss</p>
<p>(C) <input type="checkbox"/></p> 	<p>(R) Cantilever</p>
<p>(D) <input type="checkbox"/></p> 	<p>(S) Suspension</p>
<p>(E) <input type="checkbox"/></p> 	<p>(T) Arch</p>
	<p>(U) Beam bridge</p>

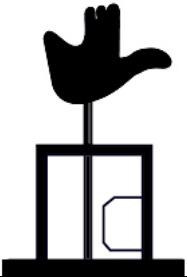

Q.3 Match the outline of the landmarks provided in Column I with their corresponding locations provided in Column II.

(5 x 2 = 10 Marks)

Column I	Column II
(A) <input type="checkbox"/> 	(P) Mahabalipuram
(B) <input type="checkbox"/> 	(Q) Sanchi
(C) <input type="checkbox"/> 	(R) Aurangabad
(D) <input type="checkbox"/> 	(S) New Delhi
(E) <input type="checkbox"/> 	(T) Bhubaneswar
	(U) Chandigarh

Q.4 Match the thumbnail images provided in Column I with the historic architectural styles they represent, as noted in Column II.

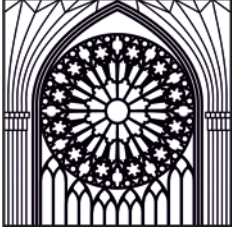
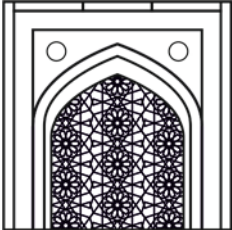
(5 x 2 = 10 Marks)

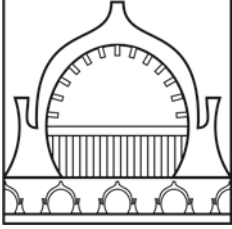
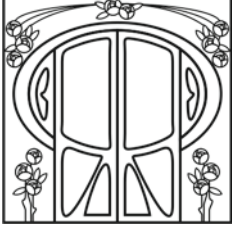
Column I	Column II
(A)  <input data-bbox="715 376 772 439" type="checkbox"/>	(P) Art Nouveau
(B)  <input data-bbox="715 680 772 743" type="checkbox"/>	(Q) Indo-Islamic
(C)  <input data-bbox="715 987 772 1050" type="checkbox"/>	(R) Buddhist
(D)  <input data-bbox="715 1294 772 1357" type="checkbox"/>	(S) Greco-Roman
(E)  <input data-bbox="715 1601 772 1664" type="checkbox"/>	(T) Gothic
	(U) Aztec

SECTION B: Geometrical Drawing (Maximum Marks: 60)

- This section contains **THREE (03)** questions. Each question carries **20** marks.

Q.5 If Figure 2 is the generative module to the Jali pattern given in Figure 1, draw the generative module for the Jali pattern given in Figure 3.

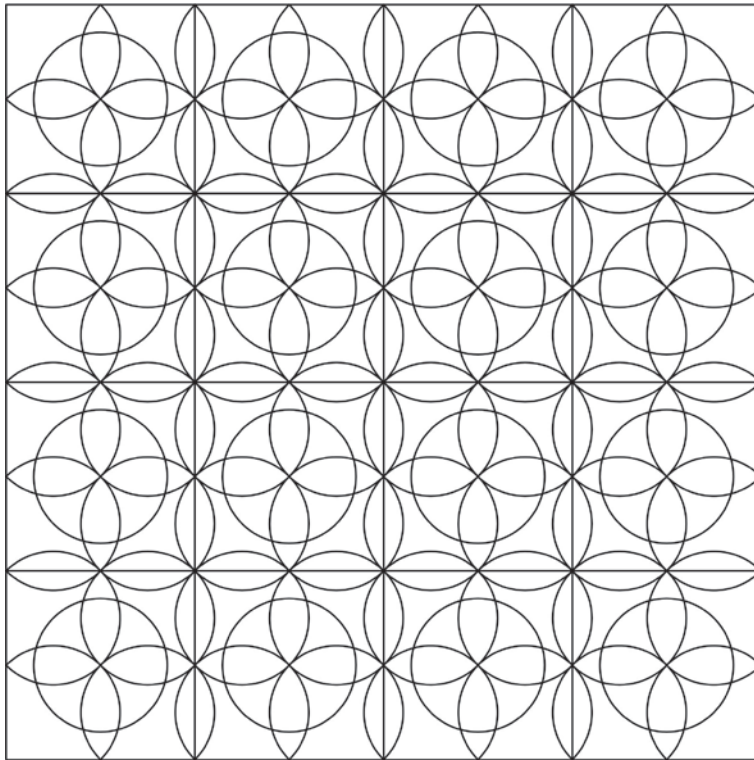

Figure 1

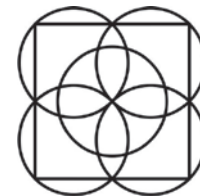

Figure 2

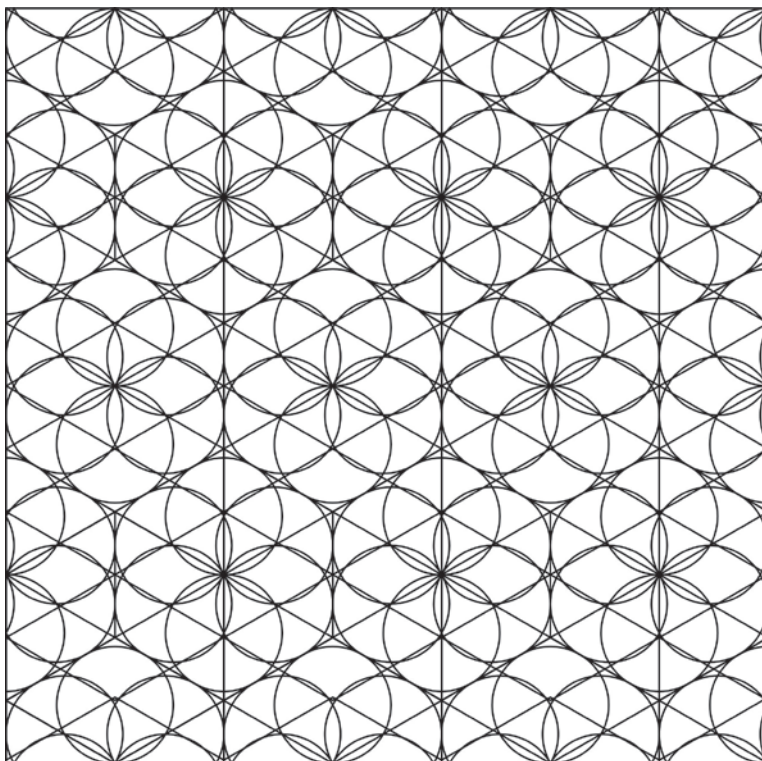
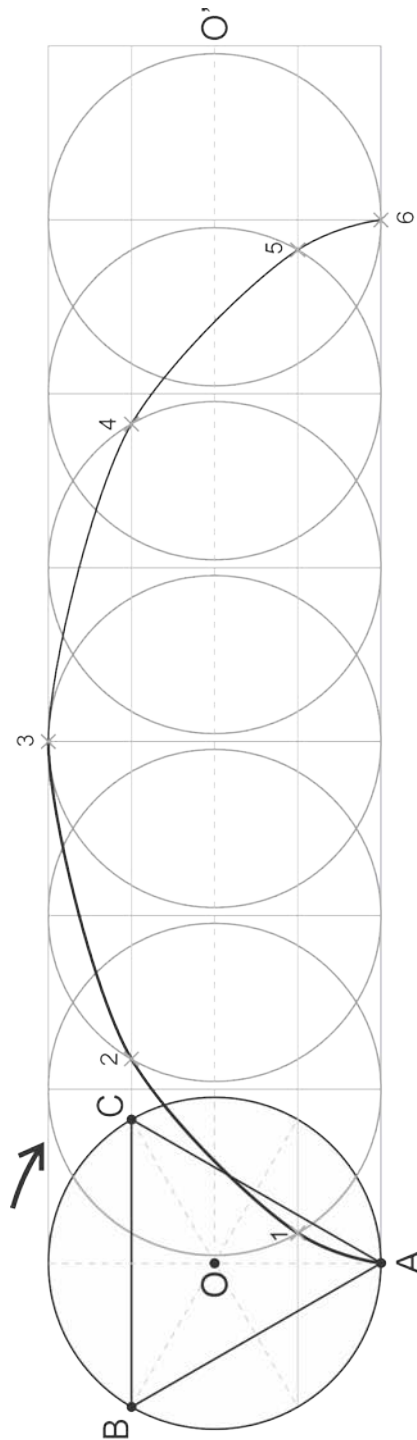
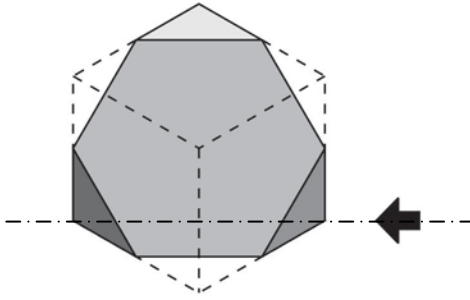

Figure 3

Q.6 A circle rolls in clockwise direction without slipping, and the point 'A' traces the curve as shown in the diagram below. Using the same principle, trace the loci of the points 'B' and 'C' in the same diagram and represent them using two different colours. The locus of the centre during forward rolling of the circle is shown using the dotted line $O-O'$.



- Q.7 A cube of 40 mm sides has been truncated by a section plane such that a regular hexagonal surface is obtained, as shown in the figure below. Draw the top view and elevation of the truncated cube from the direction of the arrow as shown in the figure. Write the angle between the section plane and the horizontal plane.



SECTION C: 3D Perception (Maximum Marks: 60)

- This section contains **THREE (03)** questions. Each question carries **20** marks.

Q.8 For the given orthographic views of an object, draw the 3-Dimensional view of the object in the space given below.

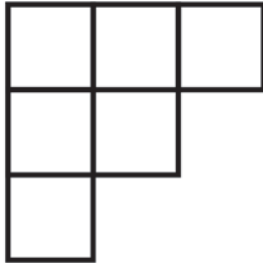

Plan

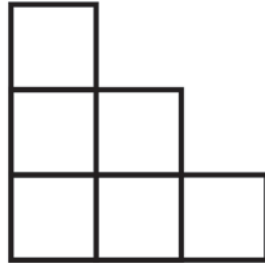

Front Elevation

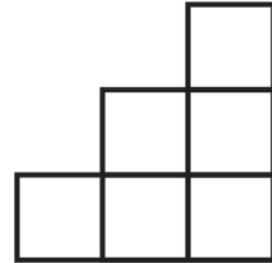

Right Hand Side Elevation

Q.9 Consider the cube, having punctures on its faces, as shown in the figure below. Each puncture has a certain depth as indicated with the number mentioned above it. Molten lead is poured from the puncture on the top. The lead flows from one puncture to the other only when they are interconnected. Draw the final shape of the solidified lead which will be obtained when all possible tunnels are filled.

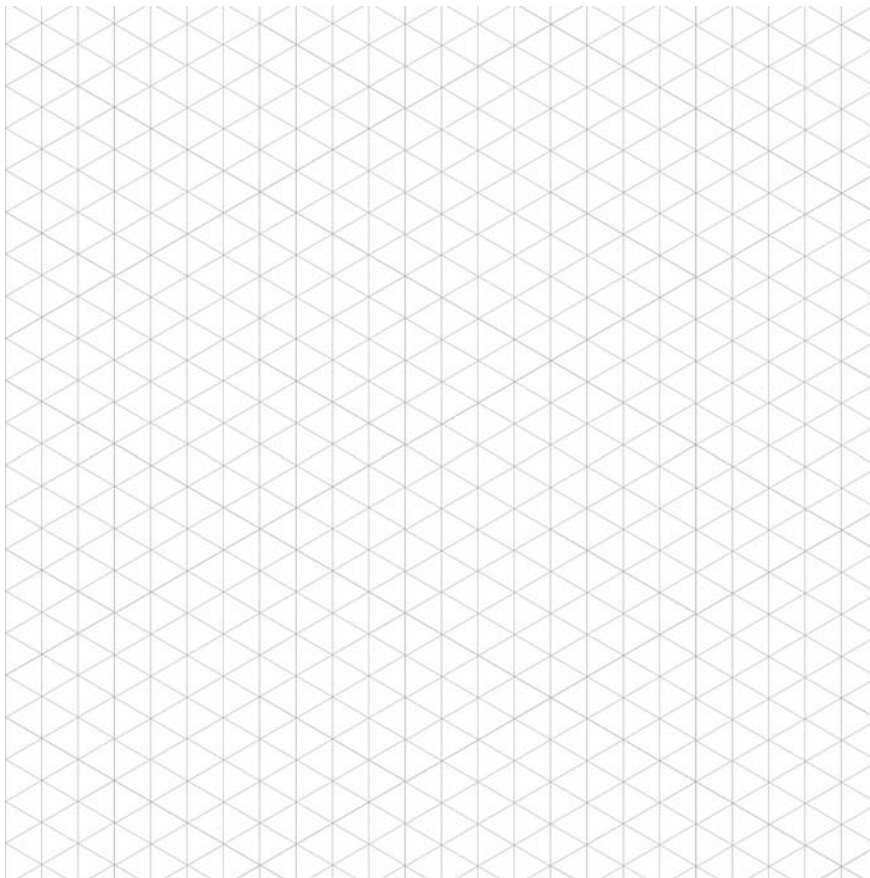
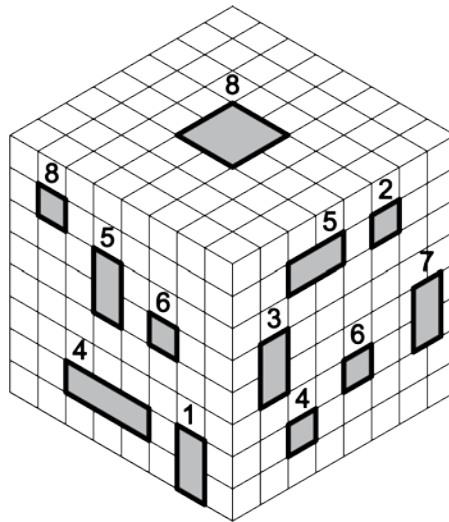

Q.10 A cuboid having height 6 units consists of two interlocking pieces. The figure below depicts the isometric view of the bottom piece. Use the grid given below to draw the isometric view of the complementary piece with the shaded plane ABCD as its base.

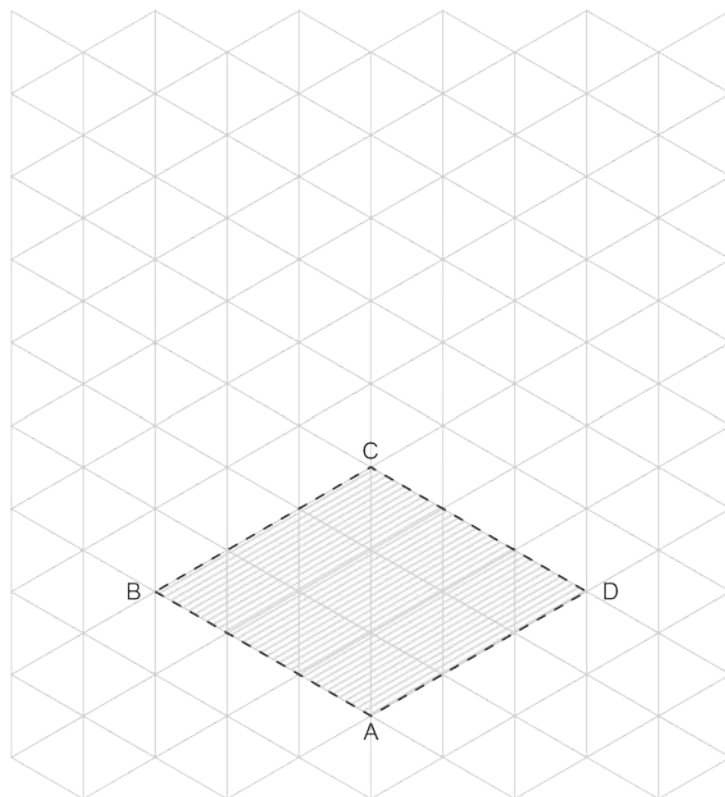
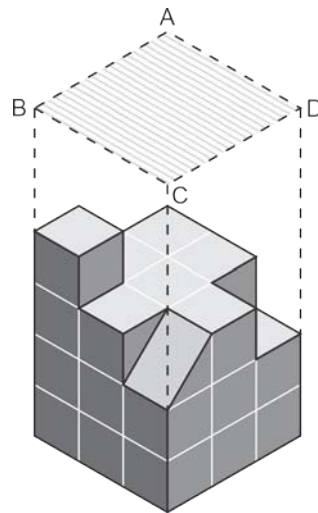

SECTION D: Imagination and Aesthetic Sensitivity (Maximum Marks: 60)

- This section contains **THREE (03)** questions. Each question carries **20** marks.

Q.11 *Imagine you are provided with empty plastic bottles and metal wire. Illustrate a creative idea to use this combination as a utility product or a decorative item. Both the objects should be used in the idea. You may use any number of these objects and change their scale and proportion. The wire may be cut if required.*

- Q.12 *Draw a dynamic, three-dimensional composition with ONE cube, ONE right circular cone, and ONE regular hexagonal prism. The solids should be floating in space and interpenetrating each other. Considering light coming from the top left, indicate shades and shadows. Only use graphite pencils for your sketch.*

Q.13 Consider the symbols for different sports as given below. Based on the design language of these graphics, design a symbol to represent Cricket: the most popular sport in India.



BOXING



FOOTBALL



HOCKEY

SECTION E: Freehand Drawing (Maximum Marks: 60)

- This section contains **THREE (03)** questions. Each question carries **20** marks.

Q.14 *Draw the sketch of a pressure cooker showing its various parts, materials and textures. Use shade and shadow to highlight the details. Preferably use graphite pencil for sketching.*

- Q.15 The diagram provided below depicts a sculpture created with a cylinder placed on top of a cuboid of the same height. An adult, a crawling baby and a housefly are viewing this sculpture from the same distance but different heights. Considering that the top of the cylinder is in the line of sight of the adult, sketch the views of the sculpture as viewed by the adult, the baby and the fly (line-drawings only).
Use the next page to draw the views.

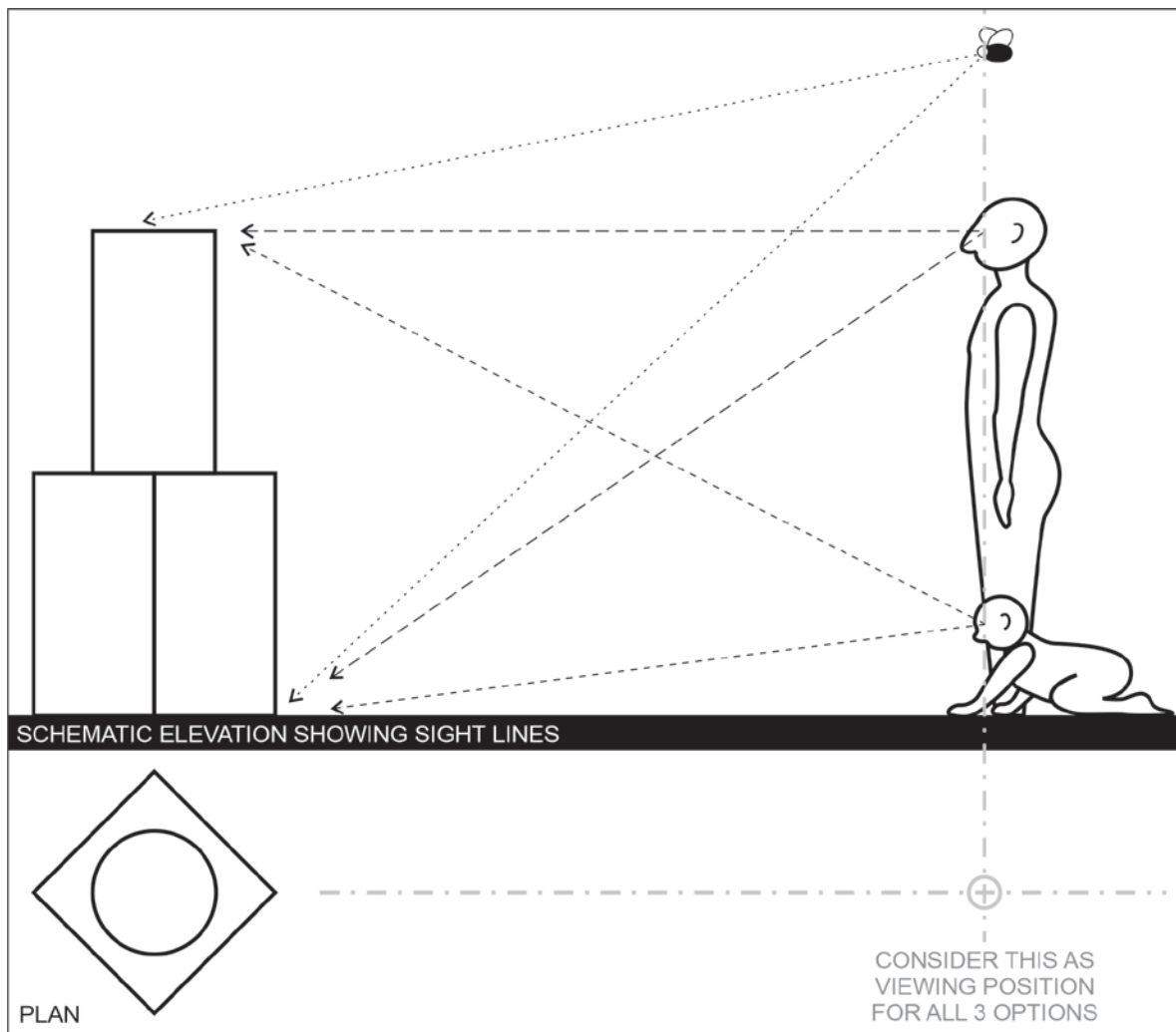

- Q.16 *Assume that you are standing in a school bus, at the back end of the aisle. There are 4-5 passengers, one conductor and one bus driver. Draw a view of the interior of the bus with appropriate details. Pay attention to proportion and scale. Render the view in colour.*

END OF THE QUESTION PAPER

SPACE FOR ROUGH WORK

SPACE FOR ROUGH WORK

SPACE FOR ROUGH WORK

SPACE FOR ROUGH WORK

SPACE FOR ROUGH WORK

DO NOT WRITE ON THIS PAGE**Section-wise Distribution of Marks**

Sections	Question No.	Page No.	Maximum Marks	Marks Obtained
Section A (Architectural Awareness)	Q. 1	XX-XX	30	
	Q. 2	XX	10	
	Q.3	XX	10	
	Q.4	XX	10	
Section B (Geometrical Drawing)	Q.5	XX	20	
	Q.6	XX	20	
	Q.7	XX	20	
Section C (Three Dimensional Perception)	Q.8	XX	20	
	Q.9	XX	20	
	Q.10	XX	20	
Section D (Imagination and Aesthetic Sensitivity)	Q.11	XX	20	
	Q.12	XX	20	
	Q.13	XX	20	
Section E (Freehand Drawing)	Q.14	XX	20	
	Q.15	XX	20	
	Q.16	XX	20	
TOTAL MARKS			300	